

Automatic Genset start/stop

There are several ways to automatically start and stop a genset:

1. potential free relay in a BMV-700. Start the genset on low battery voltage and/or low battery state of charge. See the [BMV-700 manual](#) for configuration.
2. potential free relay in our Inverters, Multis and Quattros, using the Virtual switch
3. potential free relay(s) in our Inverters, Multis and Quattros, using the [Generator start/stop Assistant](#)
4. [Automatic start stop from the Color Control GX](#)

It is also possible to combine above mentioned methods, by wiring the open contacts in parallel to each other.

Starting a genset with three-wire interface

For example Cummins/Onan gensets.

To start such a genset, the open/close contact needs to be converted into a start and stop pulse. Below solution, using standard available timing relays, does exactly that: when the open/close contact closes it generates the start pulse, and when the open/close contact opens again it generates the stop pulse.

Note that this solution should only be used on gensets that have their OWN control panel monitoring and automatically stopping on loss of oil pressure and other sensors. In other words: do not wire this directly to the starter motor and fuel solenoid.

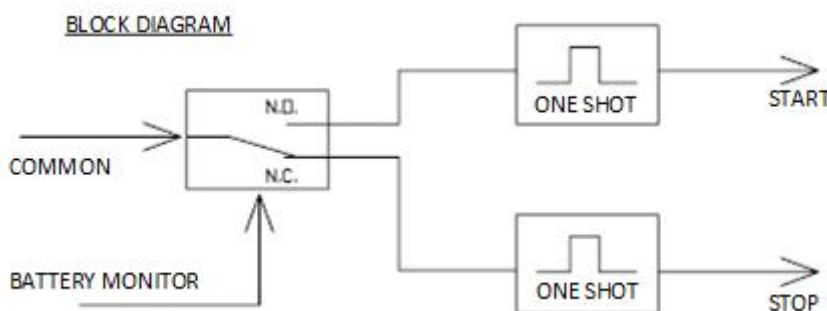

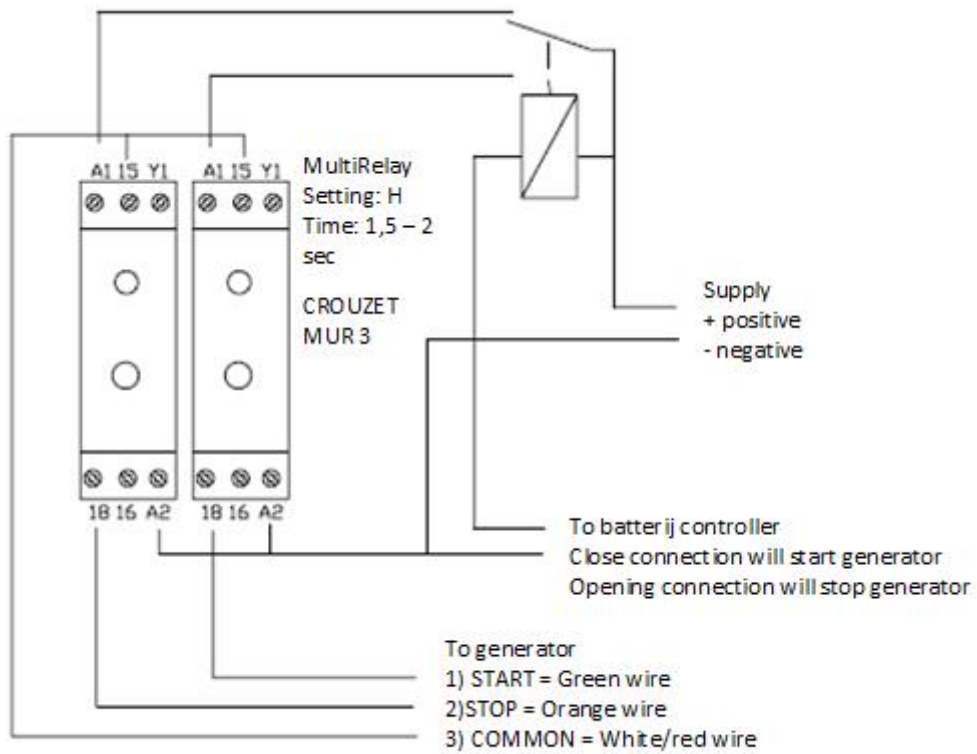

DISQUS

[View the discussion thread.](#)

From: <https://www.victronenergy.com/live/> - **Victron Energy**

Permanent link: <https://www.victronenergy.com/live/auto-generator-start-stop:start>

Last update: **2016-09-23 08:18**

