



Solis Meter and CTs Installation Guide for
SOL-RHI-3P(5-10K)-HVES-5G-DC

Application Note



Figure 1: Meter and CTs

1. Scope

This document describes the application of the Solis Meter and CTs devices used with the inverter's integrated export power control function for export power controlling. These two are a requirement for export control.

2. General notes

- i. Please read the instructions carefully before commencing with the installation. If in doubt, contact SegenSolar support for assistance.
- ii. Please Note that for export power controlling the Meter and CTs will be required in the installation.
- iii. Ensure that the correct Meter and CTs are used. If your inverter did not come with a Meter and CTs please contact SegenSolar.
- iv. The load must be switched off before commencing with installation.

3. Typical System Installation

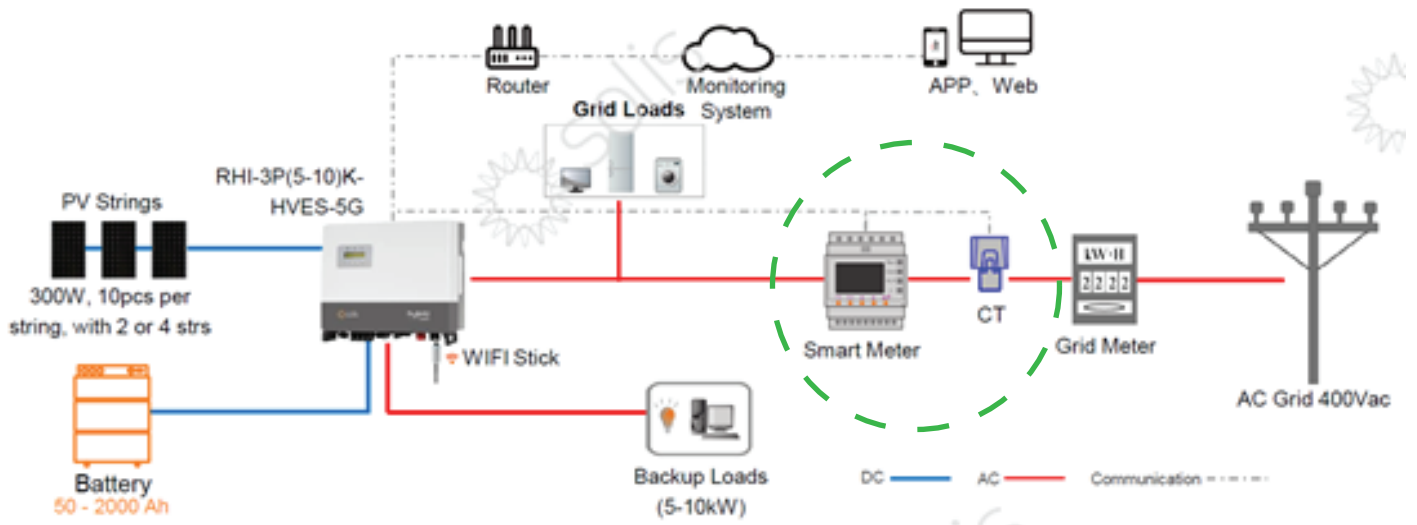

Figure 2: Installation Setup

4. System Connection Wiring Diagram

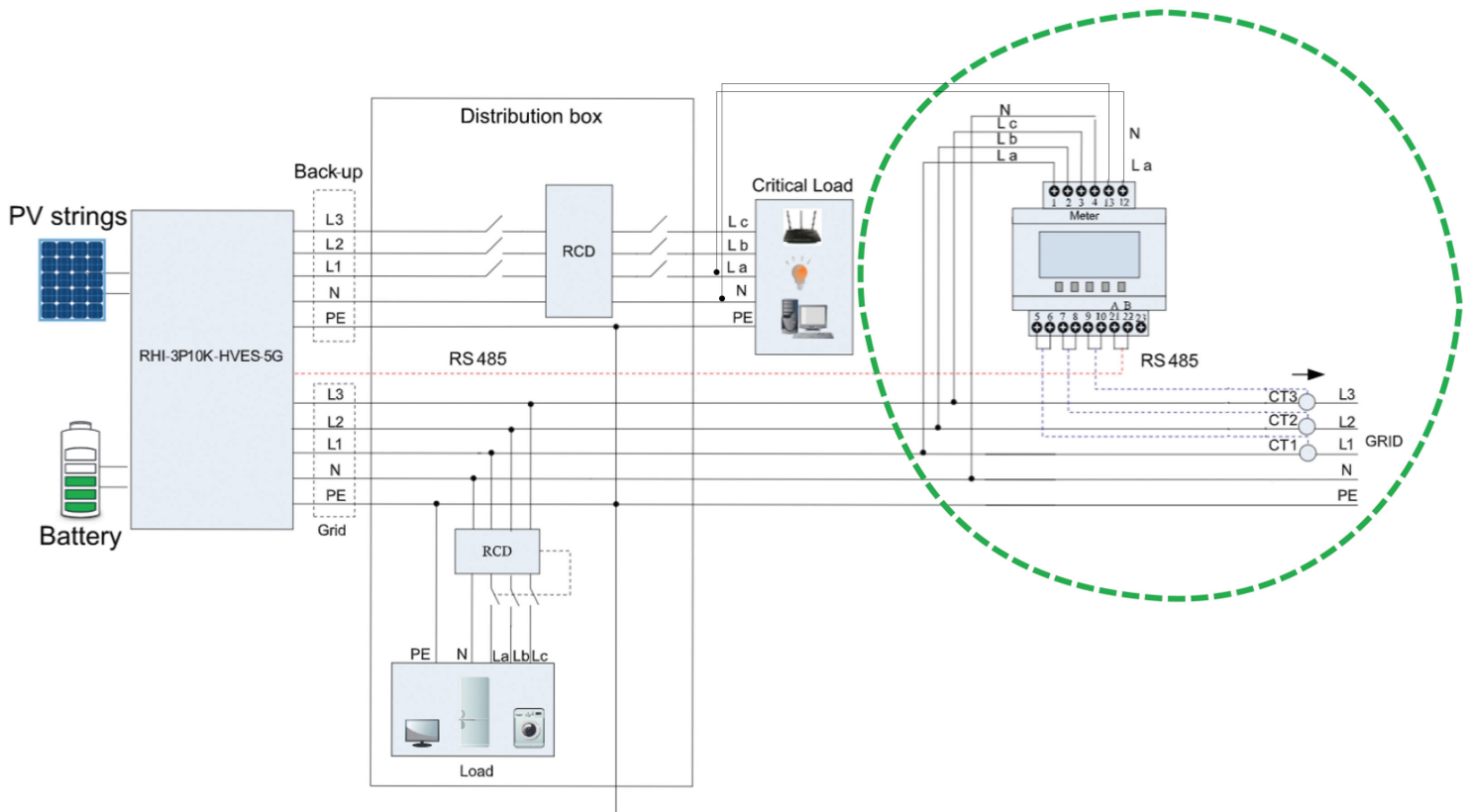

Figure 3: System Diagram

5. Detailed Cable Connection

The following figure illustrates how to connect the three-phase meter to a Solis High Voltage Inverter.

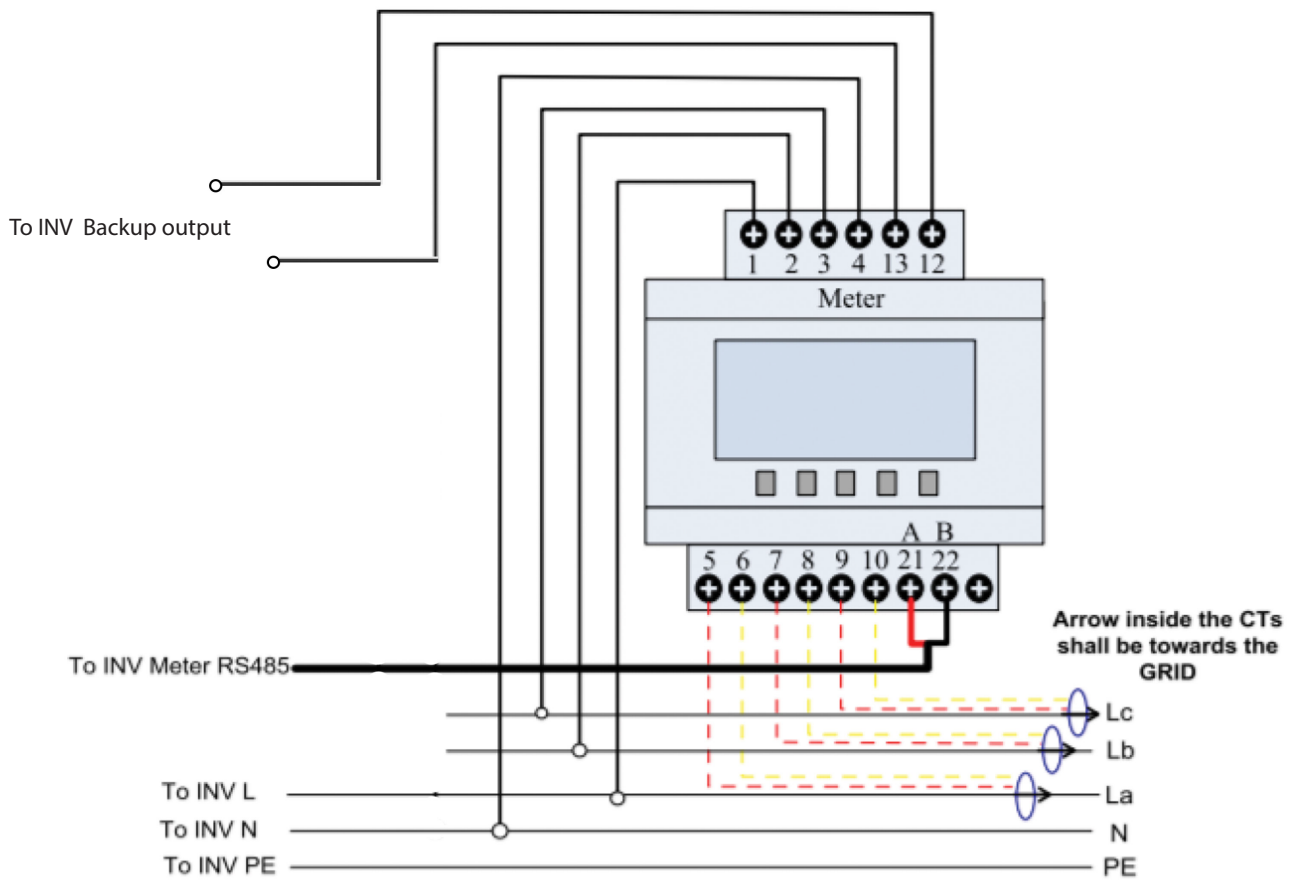

Figure 4: Detailed Cable Connection of Meter and CTs

Step 1:

The ports 5-6, 7-8 and 9-10 are the CT cable connections. Please ensure the CTs are connected with the correct polarity and the corresponding grid phase. Also, please note the small arrow inside the CTs, as shown in Figure 5, shall be pointed towards the Grid (5-6 to La, 7-8 to Lb, 9-10 to Lc) as shown in Figure 4.



Figure 5: CT directional arrow

Step 2:

1,2,3 and 4 are the voltage detection ports. Please connect the ports with the corresponding grid phases (1 to La, 2 to Lb, 3 to Lc, 4 to N) as shown in Figure 4.

Step 3:

12 and 13 are the auxiliary power source of the meter, 13 should be connected to the Neutral Wire(N) while the 12 should be connected to line La on the inverter backup output as shown in Figure 4 and Figure 3.