

Item 9182 A2 type BZ FCS

Solar fastener with cone point and umbrella washer

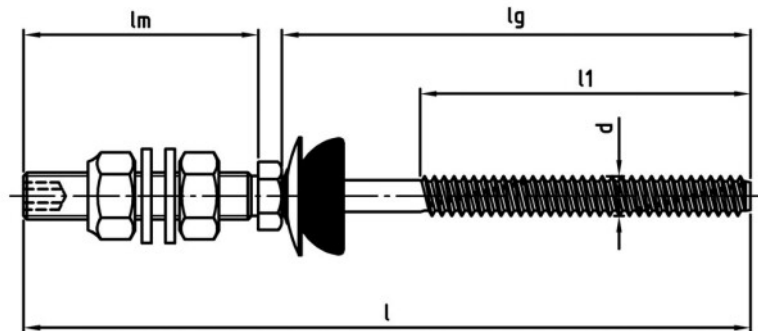

TECHNISCHE DATEN

Art.-Nr.	Item Number	91822080 80/70
VPE	Number per package	10
	Materials	A2
d	Diameter	8 mm
lg	Lg	80 mm
lm	Length of metric thread	70 mm
l	Total length	156 mm
l1	Measurement l1	70 mm
Clamp.area	Clamping area	15-55 mm
Drive size	Drive size	A/F 5
	Drive shape	Hexagonal socket

Product benefits

USES

Technical information:
 Recommended screw length = trapeze profile height/sandwich thickness + 20 mm
 The building authority approval should always be noted.

Predrilling table for substructures:

Steel thickness	Predrilled Ø
1.5 - 5.0 mm	6.8 mm
6.0 mm	7.0 mm
8.0 mm	7.2 mm
> 10 mm	7.4 mm

Area of use

Solar

FEATURES

Material

Stainless steel A2
 Austenitic stainless and anti-corrosion special-grade steel for use in damp rooms and outdoor applications without significant levels of chlorides or sulfuric acid.