

Appendix B – Manufacturer’s CLS Product Information

This form is available in a Microsoft Word version from the ENA’s website.

G100/2 - Form B - Compliance Verification Report for Customer Export or Import Limitation Schemes

This form shall be used by the **Manufacturer** to demonstrate and declare compliance with the requirements of EREC G100. The form can be used in a variety of ways as detailed below:

1. For Fully Type Tested status

The **Manufacturer** can use this form to obtain **Fully Type Tested** status for a **CLS** by registering this completed form with the Energy Networks Association (ENA) Type Test Register.

2. To obtain Type Tested status for a product

The **Manufacturer** can use this form to obtain **Type Tested** status for one or more **Components** which are used in a **CLS** by registering this form with the relevant parts completed with the Energy Networks Association (ENA) Type Test Register.

3. One-off Installation

The **Installer** can use this form to confirm that the **CLS** has been tested to satisfy the requirements of this EREC G100. This form shall be submitted to the **DNO** before commissioning.

A combination of (2) and (3) can be used as required, together with Form C where compliance of the **CLS** is to be demonstrated on site.

Note:

If the **CLS** is **Fully Type Tested** and registered with the Energy Networks Association (ENA) Type Test Register, Form C shall include the **Manufacturer’s** reference number (the Type Test Register system reference), and this form does not need to be submitted.

Where the **CLS** is not registered with the ENA Type Test Register or is not **Fully Type Tested** this form (all or in parts as applicable) shall be completed and provided to the **DNO**, to confirm that the **CLS** has been tested to satisfy all or part of the requirements of this EREC G100.

CLS Designation		Type Tested	
Manufacturer name		Ginlong technologies Co., Ltd.	
Address		No.57 Jintong Road, Binhai, (seafront) industrial Park, Xiangshan, Ningbo, zhejiang, 315712, P.R. China	
Tel	(+86)574 6578 1606	Web site	www.ginlong.com
E:mail	Ruyi.pan@ginlong.com		
CLS information			
Inverter	S5-GR3P(3-20)K,S5-GC(25-40)K,S5-GC(50-60)K,Solis-(80-110)K-5G,S5-GC(80-110)K,Solis-(80-110)K-5G-PRO		

Export Manager	Power	EPM3-5G,EPM3-5G-PLUS,EPM3-5G-PRO,EPM1-5G
General remarks: The results show that the CLS system supplied by solis meets the standard "ER G100/2-2: 2023". See below for details.		

Test

Export/Import capabilities

Export	Y / N	Import	Y / N
--------	-------	--------	-------

Description of Operation

EREC G100 section 4.2 requires a description of the **CLS**, and schematic diagram, to be provided to the **Customer**. Please provide that description and the diagram here.

The system is composed with the inverter and the export power manager.

The export power manager is installed at the grid connection point of the system and measuring the current/voltage/power data, etc. The data will be obtained by the inverter through the RS485 communication line between the inverter com port and the export power manager. Inverter will dynamically control its generation power based on the export power manager's data to guarantee the export current at the grid connection point into the distribution network will not exceed the CLS in a normal condition.

System schematic diagram is showing below:

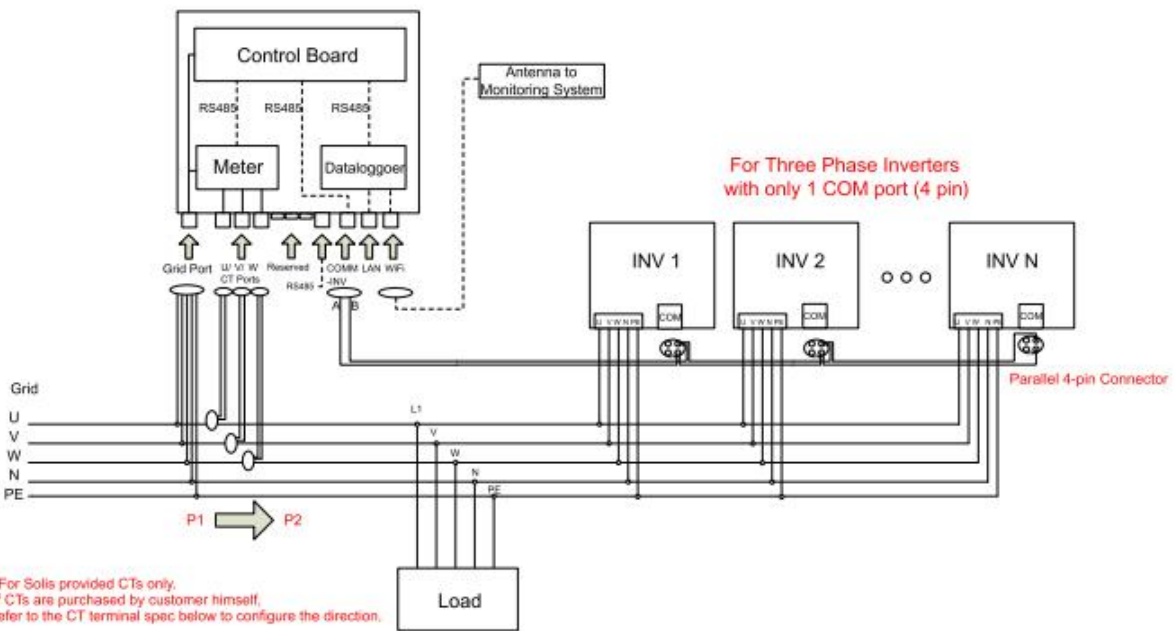

Communications Media

Document the provisions made for the use of various communication media, and both the inherent characteristics and the design steps made to ensure security and reliability.

Solis's solution CLS Internal Communications:

The communication between the inverter and the export power manager is through the hard-wired RS485 with Modbus RTU protocol with baud rate 9600. Only dedicated compatible export power manager's protocol can be recognized by the inverter to ensure the correct communication and control between the export power manager and the inverter.

Remote communications:

Solis's solution CLS systems can communicate remotely via homeowner local LAN and Wi-Fi module on the inverter, also receive instructions from Soliscloud Remote Monitoring Platform.

Cyber Security

Confirm that the **Manufacturer** or **Installer** of the **CLS** has provided a statement describing how the **CLS** has been designed to comply with cyber security requirements, as detailed in section 4.7.

We ginlong Technologies Ltd. declare that G100 certified products,

And the variant models to be included in the certification,

Are in compliance with Cyber security requirements in accordance with the standards:

- ENA Engineering Recommendation G99 Issue 1 Amendment 9 2022
- ETSI EN 303 645;

Please also refer to the documents provided (Ginlong declaration G99 and G98 Cyber and Information Security Management)

Power Quality Requirements

Where the **CLS** includes the power electronics that controls generation or loads (as opposed to the power electronics being included in **Devices** that are subject to their own power quality compliance requirements) please submit the harmonic and disturbance information here as required by EREC G5 and EREC P28.

Refer to the inverter's G98 or G99 report

Fail Safe

CLS internal failure: please submit here the description of the internal **Fail Safe** design and operation. Please also document how it has been demonstrated, including the non-volatile recording of times and numbers of state 2 operations, and confirm the overall response of the **CLS** to this internal failure.

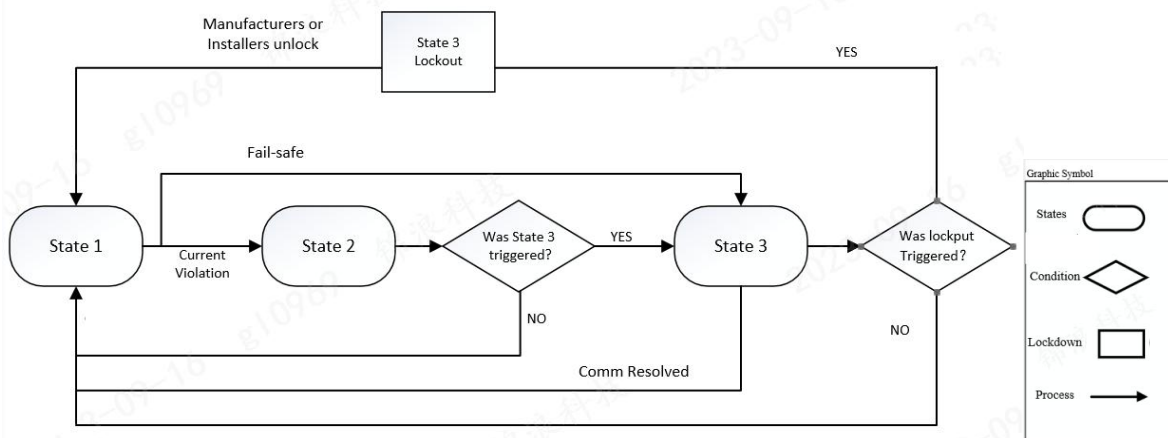

Ginlong G100 CLS was designed with a fail safe mechanism according to G100 Issue 2 2023, ensuring that in the event of communication failure or loss of source in any component, reducing the component generation to zero.

All components of the system are hardwired and will monitor in real-time whether the system is functioning properly. If a fault is detected, the system will immediately reduce the output power to zero for protection.

Communication and power supply failures between **Components** and **Devices**. Please document here compliance with EREC G100 section 5.5.

Component/Device number/description	Communication failure test	Power supply failure test
-------------------------------------	----------------------------	---------------------------

Export Power Manager	Trips Inverter internal relay in < 15s	Trips Inverter internal relay in < 15s
Inverter	Trips Inverter internal relay in < 15s	Trips Inverter internal relay in < 15s
CT	Trips Inverter internal relay in < 15s	Trips Inverter internal relay in < 15s

Operational Tests						
In accordance with EREC G100 section 5.6 undertake the tests A to D to confirm correct operation in state 1 and state 2, that transition into state 3 occurs as required, and that behaviour in state 3 is also as required.						
Test A						
Nominal Export Limit (for type tests this will be at maximum, minimum and one intermediate setting) in Amp:						159A
Nominal Import Limit (for type tests this will be at maximum, minimum and one intermediate setting) in Amp:						NA
No	Starting level	Step value	CLS registers change in level?	CLS and/or Component and/or Device initiates correct response of ≥ 5%?	Duration of step in test	Correct state 1/ state 2 operation
1	Below export limit (EL)	105% of EL	Yes	Yes	58s	State 1>State 2>State 1
2	Below export limit (EL)	110% of EL	Yes	Yes	58s	State 1>State 2>State 1
3	Below export limit (EL)	120% of EL	Yes	Yes	58s	State 1>State 2>State 1
4						
5						
6						
Test B						
Nominal Export Limit:						159A
Nominal Import Limit						NA
No	Starting level	Step value	CLS registers change in level?	CLS and/or Component and/or Device initiates correct response of ≥	Duration of step in test	Correct state 3 operation

				5%?		
7	Below export limit (EL)	105% of EL	Yes	Yes	62s	State 1>State 2>State 3
8						

State 3 Reset

These tests are to demonstrate compliance with section EREC G100 4.5.2.

Please document how the reset from state 3 to state 1 has been demonstrated. Please include how the reset is achieved.

Please confirm that for **CLSs** to be installed in **Domestic installations** three (3) resets causes lockout or that for non-domestic installations lockout can only be reset after four hours. Please explain how lockout is reset.

1. After three resets in one month, CLS state change to "State 3 - Lock-Out" in Domestic installations.
2. Expert investigation has ended successfully.
3. CLS changes system state to "State 1 - Normal Operation" and sends commands to Generation devices.
4. CLS Clears all G100 related events from its memory due to investigations.
5. Devices receive the command and enter their Normal Operational Mode.
6. CLS logs the state change.
7. CLS sends generated event to "Solis Cloud".
8. CLS sends and alert to a User Interface that the system is in "State 1 - Normal Operation".