



TEST REPORT

Manufacturer: Ginlong Technologies Co., Ltd.

Address: No.57 jintong Road,Seafront(Binhai)Industrial park,Xiangshan Demonstration Industrial Estate,Xiangshan,Ningbo,Zhejinag,315712,P.R.China

Product: Grid-connected PV Inverter

Model: S5-GR1P0.7K-M S5-GR1P1K-M S5-GR1P1.5K-M S5-GR1P2K-M
S5-GR1P2.5K-M S5-GR1P3K-M S5-GR1P3.6K-M

Use in accordance with regulations:

Technical Guidance for Customer Export Limiting Schemes G100 for photovoltaic systems with a single-phase parallel coupling via an inverter in the public mains supply.

Applied rules and standards :

The result according to G100 engineering recommendation.

The safety concept of an aforementioned representative product complies at the time of issue of this certificate of valid safety specifications for the specified use in accordance with G100 recommendations.Compliant with BSEN 61000-3-2

Certificate Number: ERD-CR202104002

Date: 2021-4-30

Manufacture Stamp

Caojiaqi
Date and place
Ningbo
2021-4-30

锦浪科技股份有限公司
GINLONG TECHNOLOGIES CO.,LTD.

System Connection Diagram

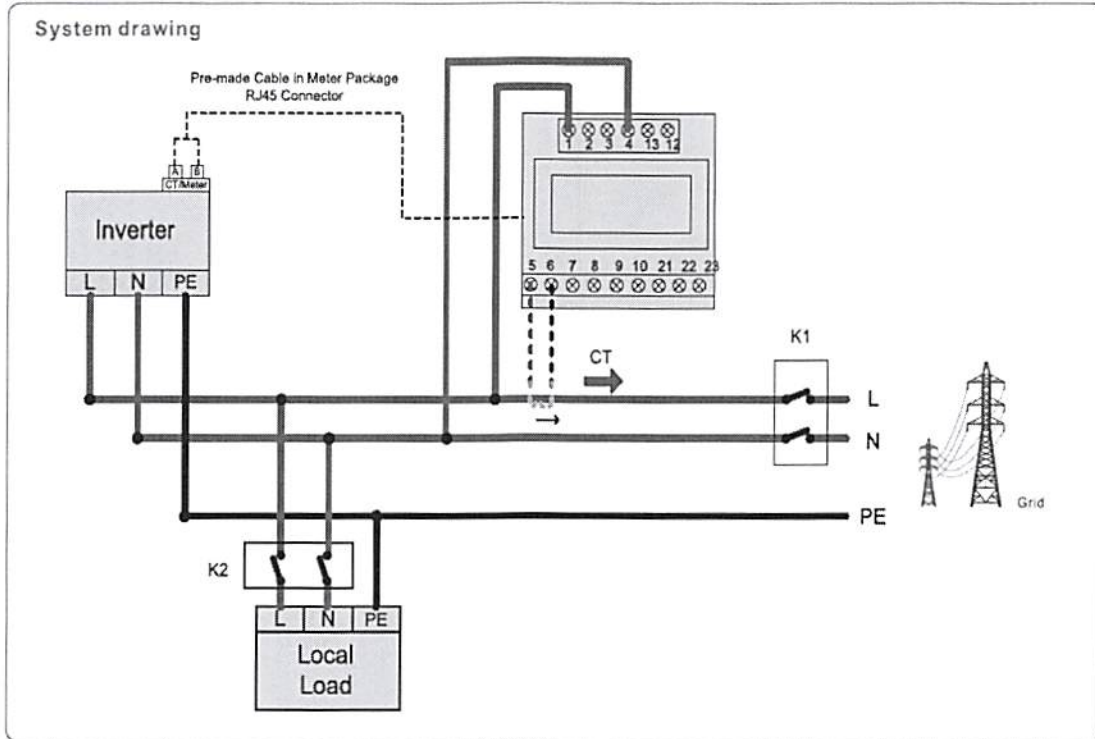

Setting Protection Test

Requirement	Result	Note
The settings is password protected, and cannot be changed by anyone other than got written agreement of the DNO;	Pass	

Fail Safe Test

Method: Set 0% export limit, implement the test before start or in running

Criteria: Fall time is less than 5s, the inverter's output active power is less than set limit. After fail safe test, disconnect AC, the reconnect time delay is fault reconnect time.

No.	Component	Test	Active Power	Response Time	Fall Time	Reconnect time	Pass /Fail	Comments
1	Remove CT	Remove CT	NA	NA	NA	NA	NA	Fail safe control function integrated inside EPM.
		Disconnect CT Cable	NA	NA	NA	NA	NA	Fail safe control function integrated inside EPM.



2	Power Monitoring Unit(PMU)	Remove Power supply to PMU	NA	NA	NA	NA	NA	NA
3	Control Unit(CU)	Remove Power supply to any CU	NA	NA	NA	NA	NA	NA.
4	Generator Interface units(GIU)	Remove Power supply to all GIUs	NA	NA	NA	NA	NA	NA
5	Demand control unit(DCU)	Remove Power supply to all DCU	NA	NA	NA	NA	NA	NA
6	Network hub/switches	Remove Power supply	NA	NA	NA	NA	NA	NA
7	PMU →CU communication cable	Unplug cable	NA	NA	NA	NA	NA	Same control unit of the EPM
8	CU →GIU communication cable	Unplug cable(repeat where additional GIU units)	NA	NA	NA	NA	NA	Fail safe control function integrated inside EPM.
9	GIU→ communication cable	Unplug cable(repeat where additional GIU units)	NA	NA	NA	NA	NA	Fail safe control function integrated inside inverter.
10	CU →DCU communication cable	Unplug cable(repeat where additional DCU units)	NA	NA	NA	NA	NA	NA
11	DCU→ Load communication cable	Unplug cable(repeat where additional DCU units)	NA	NA	NA	NA	NA	NA

12	Controlled Load(s)	Turn off load (e.g. active thermostat)	NA	NA	NA	NA	NA	NA
----	--------------------	--	----	----	----	----	----	----

NOTE: "Fail safe tests are not required at installations where all of the **Generating Units** are **Type Tested SSEGs**, with a **Power Station Capacity** of not more than 7.36kW per phase (i.e.32A per phase at 230V) and an **Export Capacity** of not more than 3.68kW per phase (i.e.16A per phase at 230V)."

Power Limit Test

Method: Set export limit, implement the test before start, then start the inverter.

Criteria: fall time is less than 5s, the inverter's export active power is less than limit power.

0%export limit [% Inverter Rating]					
Input		Input supply [% Inverter Rating]			
Load	Export/Time	25%	50%	75%	100%
Load	0%	-570W/1.1S	-920W/1.1S	-1260W/0.93S	-1458W/1.2S
[%]	25%	NA	-930W/0.98S	-1240W/0.84S	-1475W/1.2S
Inverter	50%	NA	NA	-1270W/0.88S	-1437W/0.84S
Rating]	75%	NA	NA	NA	-1466W/0.85S
25%export limit [% Inverter Rating]					
Input		Input supply [% Inverter Rating]			
Load	Export/Time	25%	50%	75%	100%
Load	0%	NA	-892W/1.1S	-1215W/0.90S	-1493W/1.1S
[%]	25%	NA	NA	-1244W/0.89S	-1475W/1.1S
Inverter	50%	NA	NA	NA	-1477W/0.94S
Rating]	75%	NA	NA	NA	NA
50%export limit [% Inverter Rating]					
Input		Input supply [% Inverter Rating]			
Load	Export/Time	25%	50%	75%	100%
Load	0%	NA	NA	-1160W/0.97S	-1498W/0.89S
[%]	25%	NA	NA	NA	-1505W/0.94S
Inverter	50%	NA	NA	NA	NA
Rating]	75%	NA	NA	NA	NA
75%export limit [% Inverter Rating]					
Input		Input supply [% Inverter Rating]			
Load	Export/Time	25%	50%	75%	100%
Load	0%	NA	NA	NA	-1479W/1.0S
[%]	25%	NA	NA	NA	NA
Inverter	50%	NA	NA	NA	NA
Rating]	75%	NA	NA	NA	NA

Comments

The test result is based on S5-GR1P3.6K-M. All the series of inverters control command are the same. So the test result can cover all series.

Note: normally, this inverter does not actively output power to the distribution network.