

Smart String Inverter

SUN2000-50KTL-M0



Smart

- 12 strings intelligent management and fast trouble-shooting
- Power Line Communication (PLC) supported
- Smart I-V Curve Diagnosis supported

Efficient

- Max. efficiency 98.7%, European efficiency 98.5%
- 6 MPPTs for versatile adaption to different layouts

Safe

- DC disconnect integrated, safe and convenient for maintenance
- Type II surge arresters for both DC and AC
- Residual Current Monitoring Unit (RCMU) integrated inside
- Fuse free design

Reliable

- Natural cooling technology
- Protection rating of IP65

Smart String Inverter (SUN2000-50KTL-M0)



Technical Specifications	SUN2000-50KTL-M0
	Efficiency
Max. Efficiency	98.7%
European Efficiency	98.5%
	Input
Max. Input Voltage	1,100 V
Max. Current per MPPT	22 A
Max. Short Circuit Current per MPPT	30 A
Start Voltage	200 V
MPPT Operating Voltage Range	200 V~1,000 V
Rated Input Voltage	600 V
Max. Number of Inputs	12
Number of MPP Trackers	6
	Output
Rated AC Active Power	50,000 W
Max. AC Apparent Power	55,000 VA
Max. AC Active Power (cosφ=1)	55,000 W
Rated Output Voltage	220 V / 380 V, 230 V / 400 V; default 3W+N+PE; 3W+PE optional in settings
Rated Output Current	76 A @ 380 Vac, 72.2 A @ 400 Vac;
Rated AC Grid Frequency	50 Hz / 60 Hz
Max. Output Current	83.6 A @ 380 Vac, 79.4 A @ 400 Vac
Adjustable Power Factor	0.8 LG ... 0.8 LD
Max. Total Harmonic Distortion	< 3%
	Protection
Input-side Disconnection Device	Yes
Anti-Islanding Protection	Yes
DC Reverse-Polarity Protection	Yes
PV-array String Fault Monitoring	Yes
DC Surge Arrester	TYPE II
AC Surge Arrester	TYPE II
Insulation Detection	Yes
Residual Current Monitoring Unit	Yes
	Communication
Display	LED Indicators, Bluetooth + APP
RS485	Yes
USB	Yes
PLC	Yes
	General
Dimensions (W x H x D)	1075 x 555 x 300 mm (42.3 x 21.9 x 11.8 inches)
Weight (with mounting plate)	73 kg (161 lb.)
Operation Temperature Range	-25 °C ~ 60 °C (-13 °F ~ 140 °F)
Cooling	Natural Convection
Max. Operating Altitude	4,000 m
Relative Humidity	0~100%
DC Connector	Amphenol Helios H4
AC Connector	Waterproof PG Terminal +OT Connector
Protection Rating	IP65
Topology	Transformerless

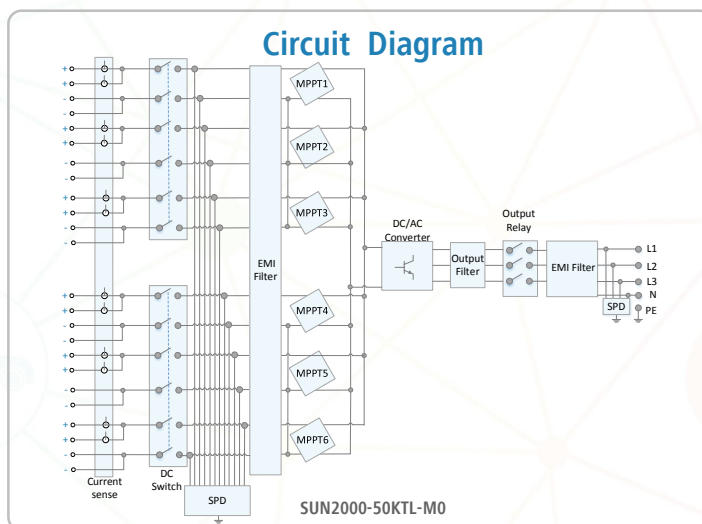
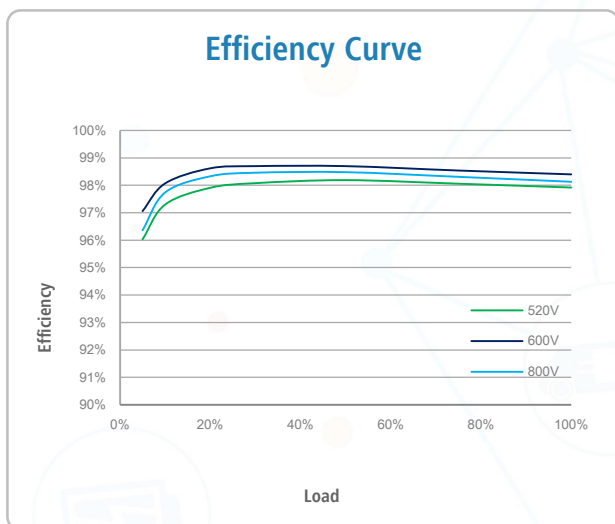

The text and figures reflect the current technical state at the time of printing. Subject to technical changes. Errors and omissions excepted. Huawei assumes no liability for mistakes or printing errors. For more information, please visit solar.huawei.com. Version No.:01-(201801)