



Installation Manual

LiTE Home and Business 52V

Range of Lithium Iron Phosphate Battery Modules

Manufactured By Freedom Won (Pty) Ltd

Kimbulk Industrial Park, Unit C3 & C4

9 Zeiss Road

Laser Park, Honeydew

2040

South Africa

www.freedomwon.co.za

Technical and Installation Assistance – Contact:

Please contact your Freedom Won Distributor or Reseller Installer for technical and installation support. A directory of Distributors and Reseller Installers is available at www.freedomwon.co.za.

For advanced support please contact support@freedomwon.co.za.

Update Record:

Revision Number	Update Summary	Updated By	Date of Issue
12	Incorporated new model names and warranty to reflect guaranteed performance at 80% average DoD.	Antony English	28 April 2020
13	Updated dimensions and weights of 5/4, 10/8, 15/12 and 20/16 models to new design.	Antony English	13 August 2020
14	Updated battery images with updated display features.	Jaco De Beer	14 August 2023

1. Introduction

This manual is intended to aid an installer with the installation and commissioning of the range of **Freedom Won LiTE** lithium iron phosphate (LiFePO₄) energy storage modules. This document is not intended to provide detailed information of the inner workings of the Freedom Won LiTE energy storage modules that is not relevant to a person that is performing the installation and final commissioning. Supplementary information relating to programming of the built-in battery management system for specific applications is available to approved integrators directly from Freedom Won.

This manual does not attempt to cover all the details pertaining to the setup of third-party equipment in relation to the interface and necessary functionality to work with the LiTE energy storage modules. Freedom Won however is available at the contact details on page one to provide direct support where necessary for supported inverter brands.

2. Product Description

The Freedom Won LiTE technology is available in various standard sizes to meet all residential, commercial and industrial applications, ranging in models from 5kWh up to 2500kWh. Larger systems are provided by Freedom Won based on specific project requirements by installing multiple units of the same model battery in parallel.

Freedom Won offers the following ranges in the LiFePO₄ technology:

1. LiTE 12V
2. **LiTE Home and Business**
3. LiTE HV Home and Business
4. LiTE Marine
5. LiTE Mobility (golf carts, forklifts etc)
6. LiTE Commercial (including Lite Commercial HV and HV+)
7. LiTE Industrial

This manual covers the standard voltage models of the **LiTE Home and Business** range from 5kWh up to 80kWh. Please refer to the manuals specific to the other ranges.

The standard LiTE voltage is 52V nominal (to suit 48V systems). The LiTE HV range is designed for specific higher voltage inverters such as those from Ingeteam (Ingecon 1Play 3TL and 6TL). The LiTE Commercial range varies from 52V to 800V depending on customer requirements (including the HV and HV+ models). The LiTE Industrial range varies from approximately 500V to 800V depending on customer requirements.

The LiTE Marine range of lithium batteries is available on request with similar specifications to the Home range, including 13V and 26V options to suit 12V and 24V systems respectively. These models are water resistant (IP65) and designed for mounting on the floor or horizontal deck and have dimensions that are different to the LiTE Home models. For more information on these models please contact Freedom Won.

Table 2.1 provides an overview of the 52V LiTE Home and Business range. There are eight LiTE models in the Home and Business range, as included in the table, classified in terms of energy capacity.

An image with numbered labels pertaining to the following paragraphs is provided in Figure 2.1. The model number denotes with the first number [1] the total energy storage capacity in kWh of each model. The second number [2] denotes the average amount of energy in kWh that should be withdrawn per cycle (on average) in order to optimise the life of the lithium cells. This equates to 80% of the total for each model i.e. 80% depth of discharge (DoD). **Note that all Freedom Won LiTE batteries offer a maximum of 90% DoD as standard.**

The range is very compact with the "Home" models up to the LiTE Home 20/16 intended to be wall mounted (floor mounting is also possible – all models are supplied standard with plastic feet). The larger "Business" range is designed for floor standing with aluminium feet with plastic pads on the underside.

The Ah capacity is also provided in the tables for each model for easy reference.

The maximum current for each model is governed by the rating of the built-in circuit breaker [3], which has been sized below the maximum current capability of the lithium cells. There is no noticeable cell temperature rise during operation and no active cooling of the cells is required. The time limit for operation at the maximum current is 30 seconds in a 40 second cycle. To ensure that the circuit breaker does not trip in normal operation it is advised that the design of the system aims to remain at or below the continuous current value.

For the 52V models the absolute maximum allowable voltage when fully charged is 56V, however a more typical inverter charge setting range is 55.5V to 55.8V, depending on the inverter voltage tracking accuracy. The voltage normally used as the minimum cut off is 48V, however this will not typically be reached when operating down to 90% Depth of Discharge (DoD). The Battery Management System (BMS) will command the connected inverter with CAN Bus interface to stop discharging the battery at 10% SoC (90% DoD), which roughly equates to 49,0V). Under high load the voltage may drop to 48V whilst still above 10% SoC. A voltage of 48V or even lower can be observed in systems without a CAN Bus interface or where the standby current draw on the inverter has caused the battery to be discharged below 10% SoC. The battery breaker will eventually trip the battery at around 47V to protect the cells from undervoltage.

Figure 2.1 Labelled Image of the Freedom LiTE Home 15/12
(Labelling corresponds with the text)

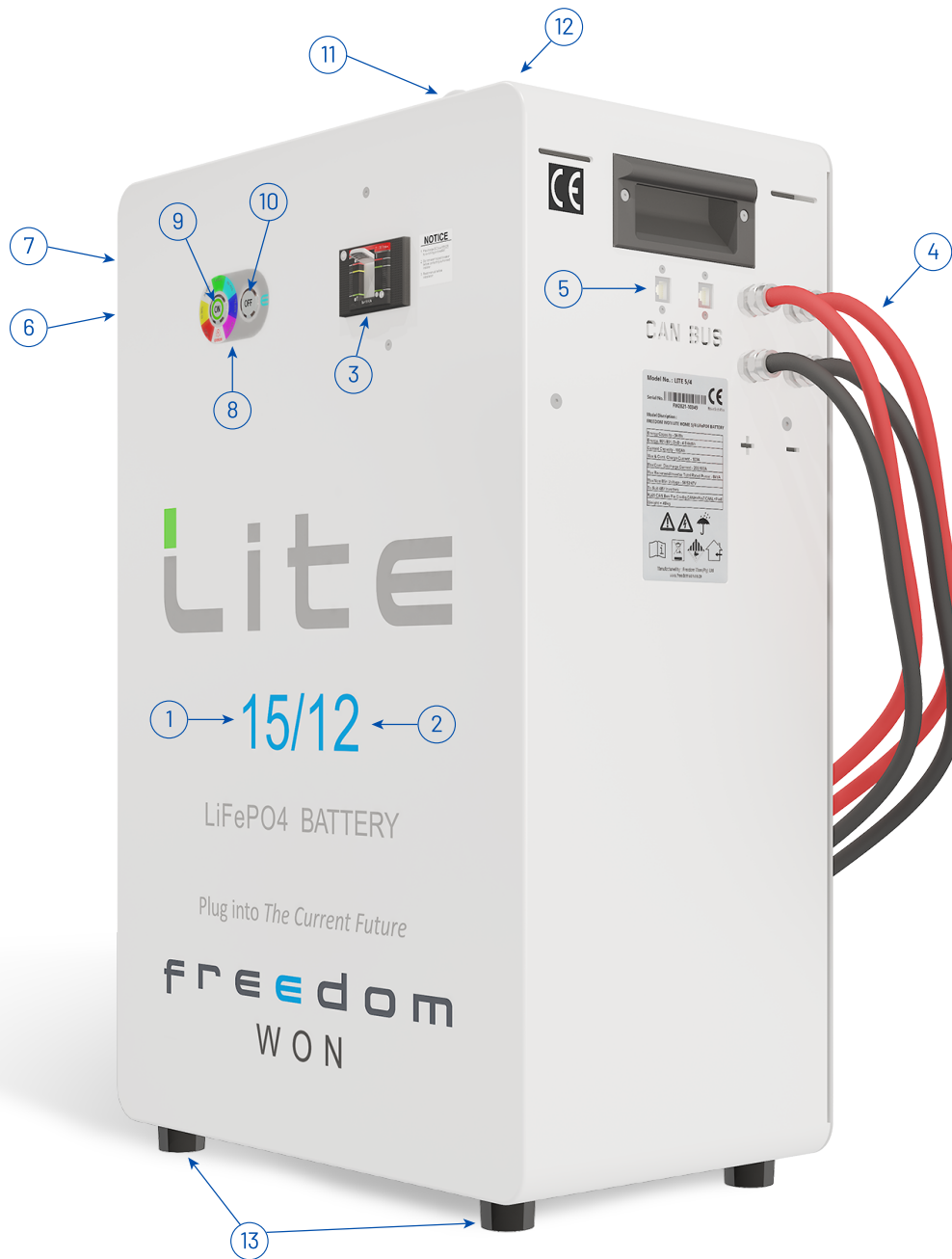

Note: Diagram above is applicable to the following HOME range batteries:
10/8, 15/12 and 20/16. 30/24 units incorporate a digital SoC display in
place of the colour wheel SoC display.

1. Gross Capacity
2. 80% Capacity recommended for daily cycling (max available is 90%)
3. Breaker
4. Power Cables

5. CAN Bus Sockets x 2 (RJ45) (one socket must contain a termination resistor if end of line)
6. USB Programming Port (not visible in photo). Note that in models manufactured prior to May 2020 this port is a DB9 plug.
7. Reset Button (not visible in photo)
8. State of Charge / Error Colour Wheel Display
9. On Button
10. Off Button
11. Lifting Eye Bolt Hard Point (not visible in photo)
12. Safety Retaining Tab for Floor Mount Option (not visible in photo)
13. Feet

The weight of each model is given in the tables. The Freedom Won LiTE Home 5/4, 10/8 and 15/12 models can be manually lifted by two people onto its hanging points. The larger units may require lifting equipment of varying degrees for handling and installation as explained later in this document.

The dimensions given are for the principle outlines of the aluminium housing and exclude items that protrude such as the DC cable glands and the circuit breaker handle.

The DC cables exit the unit through glands located on the **top right-hand side** of the casing and vary in number according to the model [2 in Figure 2.1]. The correct cable lugs for connecting these leads to the inverter must be in hand when doing an installation. If there are several inverters and charge controllers that need to be connected to the battery, it is advisable to install a DC connector box to use as a junction point from which to branch out to all the battery connected equipment.

Table 2.1 LiTE Home and Business 52V Range Overview

Freedom Won LiTE	Home 5/4	Home 10/8	Home 15/12	Home 20/16	Home 30/24	Business 40/32	Business 60/48	Business 80/64
Total Energy Capacity [kWh]	5	10	15	20	30	40	60	80
Energy, 80% DoD [kWh] (1)	4	8	12	16	24	32	48	64
Energy, 90% DoD [kWh]	4,5	9	13,5	18	27	36	54	72
Current Capacity [Ah]	100	200	300	400	600	800	1200	1600
Max & Cont. Charge Current [A](2)	100	200	300	400	600	600	800	800
Max & Cont. Charge Power [kW](2)	5	10	15	20	30	30	40	40
Max/Cont. Discharge Current [A](2)	200/100	300/200	480/300	480/400	750/600	750/600	1000/800	1000/800
Max/Cont. Discharge Power [kW](2)	10/6	15/10	24/15	24/20	38/30	38/30	50/40	50/40
Max Recommended Inverter Total Rated Power (cont.) [kVA]	8	10	15	15	25	25	35	35
Nominal Voltage [V]	52V, to suit 48V Inverters, min 47V, max 56V							
Weight [kg]	49	89	130	173	310	412	613	811
Dimensions on or against wall - Height x Width x Depth [mm]	500x340x290	745x340x290	745x490x290	745x640x290	1540x455x370	1895x584x310	1895x859x310	1895x1142x310
Enclosure	Aluminium - powder coated white front, rated for indoor use							
DC Connection - Integrated Cables, [no. per electrode](3)	1x 50mm ²	1x 50mm ²	2 x 50mm ²	2 x 50mm ²	2 x 95mm ²	2 x 95mm ²	2 x 95mm ²	2 x 95mm ²
Control Interface	RJ45 Socket x 2 - CAN Bus for interfacing with compatible inverters and system controllers, and communication for the connection of parallel batteries - note that parallel batteries must all be of the same model.							
Protection	Shunt Trip Circuit Breaker sized to suit max current, can be tripped by BMS if critical fault, manual reset. Includes overcurrent, cell under and over voltage, temperature, weak cell detection, minimum SOC control							
Human Interface	State of Charge Display (0 to 100%), Error light, Error Reset Button, USB Plug for Programming, WiFi remote monitoring (optional accessory)							
Warranty [4]	10 years or 4 000 cycles for average 80% DoD, and max 90% DoD							
Service Life [4]	>16 years (>5 500 cycles) expected life at 80% DoD (1), >20 years (>7 500 cycles) at 50% DoD							
Essential Accessories	Note that for connecting the battery to a PC a USB "printer" cable is required (one is supplied with each battery) CAN Bus Termination Resistor - one required per battery (one included with battery) CAN Bus Cable (RJ45 LAN Cable) - one required per battery (not supplied with battery). Note some inverters will require a special (non-standard pin configuration) cable - see installation manual							

Notes to Table 2.1

- 1) DoD = Depth of Discharge, recommended 80% DoD for average daily discharge, 70% DoD on average for optimal life – max for normal operation 90% DoD, max for system in standby 100% DoD.
- 2) Max load duration – 30 seconds per 40 second cycle. 1.5 x Max overload can be handled for 5 seconds.
- 3) Fly Leads 1,8m long, power cable Red = Positive, Black = Negative, conductors in table refer to one electrode i.e. per positive and negative connections
- 4) End of Life (EoL) defined as cell dropping to 60% of Beginning of Life (BoL) capacity for expected life and 70% of BoL capacity for warranty. This warranty applies to LiTE units sold after 1 September 2019. For LiTE units sold prior please contact Freedom Won for warranty information.

Two RJ45 sockets [6] are provided, one for connecting the CAN interface from the battery to the system controller or directly to the inverter depending on the brand, and another for connecting the battery to another battery or for a termination resistor (more detail later in manual).

A USB Type B “printer” plug [7 – concealed] is fitted to the upper left-hand side of the housing for use by technicians for programming the required profile onto the BMS or updating firmware. The required profile is typically loaded by Freedom Won prior to delivery but installers are advised to obtain the correct cable to allow Freedom Won or the distributor to program batteries remotely on behalf of the installer via the installer’s Windows laptop, if necessary. One cable is provided with each battery.

An error reset button [8 – concealed] is positioned adjacent to the USB plug.

LiTE units are also fitted with a State of Charge (SoC) display [9], which includes a red LED error indicator [10] and below it a “low power” indicator.

Figure 2.2 USB Type B “Printer” Cable for Programming LiTE units



The ON button [9] and OFF button [10] are located on the colour wheel SoC display.

All LiTE units have feet as standard, whether needed or not [15].

A hard point is supplied on the top for the 15/12 and 20/16 models [14] for inserting an eye bolt that can be used for hoisting the battery onto the wall mountings. The LiTE 30/24 and above are supplied with permanently installed eye bolt(s).

3. DC Bus Design Notes

The LiTE range includes an integrated battery DC breaker/isolator that breaks the positive cable continuity inside the battery. This breaker, on all Home and Business models, is rated for a 36kA fault (short circuit) current. The system therefore does not require another DC isolator or breaker except where required in relation to conformance with the [Clean Energy Council of Australia battery design Best Practice Guide](#), which states that, should the internal battery isolator not offer isolation of BOTH the positive and negative terminals of the battery, an external isolator is required that can isolate both the positive and negative cables/terminals of the battery.

The approximate short circuit current values of each battery model are provided in the table below:

Table 3.1 Short Circuit Current for LiTE Home and Business Models

Freedom Won LiTE	Home 5/4	Home 10/8	Home 15/12	Home 20/16	Home 30/24	Business 40/32	Business 60/48	Business 80/64
Short Circuit Current [A]	1500	2100	3100	3600	4700	5100	5800	6200

The external isolating device required for installations in Australia should be designed to withstand these fault levels (short circuit currents).

4. Transport, Handling and Mounting

The Freedom Won LiTE units are packaged in protective layering and fastened into a wooden crate with pallet type feet, which allow lifting with a forklift or a pallet jack. The LiTE Home 5/4 and 10/8 models are easily handled by two people. The LiTE 15/12 and 20/16 models may be manually handled by four or six people. The LiTE 30/24, 40/32, 60/48 and 80/64 models must be handled with care by a forklift or pallet jack of the required lifting capacity rating.

If it is necessary to transport the larger units (typically LiTE 40/32 and larger) up or down multiple stairs in order to get them to the point of installation in the premises it may be preferable to deliver the unit with the lithium cell modules separate and then Freedom Won will fit them into the unit on site. This must be arranged with Freedom Won at the time of order placement and will attract a nominal fee for labour plus transport and accommodation where applicable. This service is not available in all countries. Please enquire with Freedom Won Sales.

The “Home” series is designed for wall mounting to preserve room and floor space and offer a convenient obstruction free and aesthetically pleasing solution. Each model is fitted to the wall using two Rawl Bolts. The Rawl Bolts are inserted into correct diameter predrilled holes in the wall. **The bolts must first be tightened substantially so that the internals of the Rawl Bolt have gripped tightly into the wall, and then the bolt must be turned out slightly with the head protruding so that about 5mm of the bolt shank is visible. This pre-tightening prevents the bolt from being pushed into the wall when mounting the LiTE unit.** Freedom Won LiTE units have two keyhole shaped holes on the back, which are shaped to fit over the bolt heads and then a narrowed section secures around the bolt shank as the unit is lowered into its final position. The 5/4, 10/8 and 15/12 models are hung using M8 bolts whilst the 20/16 and 30/24 models are hung on M10 bolts. The centre to centre spacing of these bolts must be applicable to the model being installed. It is critical that these bolts are mounted within 1mm of the correct dimension and must be **perfectly level**.

Figure 3.1 Bolt Mounting Keyhole on Rear of the LiTE unit Casing – floor mount retaining tab and fitted eye bolt also visible



Eye bolts fixed to the top of the LiTE unit can be used for hoisting it up to the required height for fitting to the wall (excluding LiTE 5/4 and 10/8, which can be lifted manually). The eye bolt(s) on the models up to the LiTE 20/16 can be removed after installation. Ensure that you have one M12 x 1,75 thread eye bolt rated for 450kg or more for the models that are not supplied with permanently fixed eye bolts.

Lifting the batteries by the eye bolts should be performed using a mobile gantry crane or a high lift pallet jack.

Figure 3.2 Eye bolt Example



Figure 3.3 Eye bolt Installation on a LiTE 15/12 model (remove after installation)



The units can alternatively be lifted to the right height and onto the hanging bolts using a high-lift pallet jack such as shown in Figure 3.4.

A site assembled gantry with electric winch is shown in Figure 3.5. This gantry is available from Freedom Won as an accessory and is available with various gantry widths.

Figure 3.4 High Lift Pallet Jack



Models up to LiTE Home 20/16 are fitted with lifting or manoeuvring handles to make placement easier. See Fig 4.2.

Fig 3.5 Site Assembled Gantry with Electric Hoist



Caution:

1. Great care must be taken to ensure that the Rawl Bolt has properly located into the narrowed section of the mounting hole before removing the support.
2. Handle the LiTE unit with great care when lifting and manoeuvring. It should remain either lying flat on its back, on a long side, or vertically upright (it should not be placed upside down or on its front face). When manoeuvring through a doorway on its long side be certain to pack spacing foam to prevent damage to the plugs and glands.
3. Do not allow the pallet jack to over centre if it is a model with forks longer than the lower arms.
4. Take care not to knock any of the protruding items against obstacles during handling such as the DC cabling and plugs and the circuit breaker handle.
5. Take care not to scratch the unit during handling. Packaging foam should be used to protect the paint when being handled on a trolley or pallet jack.
6. Always ensure that lifting equipment and slings are adequately rated for the lifting weight.
7. Ensure that the eye bolts are fully screwed into the hard point thread on the top of the unit before lifting.
8. Wear personal protective equipment such as safety shoes and gloves while handling and mounting the LiTE unit.

9. Always ensure that you have enough people on hand to perform the operation safely, i.e. at least one person to guide and stabilise and one person to hoist or handle the pallet jack or gantry.
10. The gantry can be configured for wall mounting – when using the gantry in this configuration absolute care must be taken to prevent the gantry from being pulled over by non-vertical tension on the rope.

Mounting and Environmental Requirements

The LiTE Home and Business models are designed strictly for indoor use away from moisture and direct sunlight.

No specific venting is required since the LiTE unit emits no hazardous gases, however air circulation may be required to ensure room temperature is maintained at reasonable levels, preferably below 30°C (see LiTE range warranty for information upper temperature limits for hot environments).

Room heating may be required in cold climates to keep the room above 0°C, since charging of the LiTE unit is not permitted below 0°C. Ambient environments that regularly exceed 40°C should employ room cooling if practicable to ensure optimal service life.

Temporary storage or transport of the LiTE unit is permitted in the range -20°C to 45°C, however extended storage should be between 0°C and 30°C.

The LiTE unit may be mounted directly against a wall or on the floor. There is no minimum requirement for spacing around the unit from other objects, provided that these objects do not generate heat and that the vents on the sides of the unit are not blocked. Note however that access is required to the USB programming port on the left side, and the CAN Bus plug sockets and cable exits on the right side.

The LiTE unit should be installed at least 500mm way from a heat source.

The LiTE Home and Business IP rating is IP20. The breaker is rated for IP40.

5. Connecting the Freedom Lite

5.1 Power Cables

The LiTE unit is simple to connect to the inverter. First of all you will connect the 48V positive and negative cables to the inverter terminals using the applicable lugs.

Caution: Prior to connecting the positive and negative cables to the inverter be sure to check that the main battery circuit breaker is switched off. This will ensure that there are no short circuits between the loose ends of the cables.

The cables are supplied with the LiTE unit, permanently fixed into the unit and secured onto the casing using compression cable glands.

Attach crimp lugs to the ends of both cables ensuring that the correct terminal size is used and the lug is matched to the size of the cable. The positive cable is red and the negative cable is black. This is confirmed by + and – signs on the battery casing beside the respective cables. See Tables 2.1 for the cable size and quantity fitted to each LiTE unit. The cable cross sectional area is based on an acceptable voltage drop with the inverter being mounted on the wall adjacent to the battery so that the cable run is less than 5m (Note: however that the standard cable length is 1,8m, longer cables available on request).

Cable runs longer than 5m should be assessed and larger cables considered for extending the LiTE unit cables to minimise voltage drop. Double Insulation welding cable is recommended.

The cables may be routed through trunking and connected into the inverter on the positive and negative terminals respectively. The inverter terminals on most inverters can then be used for linking up the charge controller(s) to the DC Bus. On Installations where there are too many inverters and/or charge controllers to connect to the DC bus using the inverter terminals as a junction point a DC connector box is required. Where more than one cable is fitted per pole, the battery cables can be separately routed directly to separate equipment (inverters and charge controllers) – if this is done the installer must take care to ensure that any one of the cable pairs will not be overloaded. The cables for each pole are connected together inside the battery.

5.2 Control Cables – Overview

For controlling external devices, you will need to connect the CAN Bus cable that allows the BMS inside the LiTE unit to control and interface with these devices.

The CAN Bus connection is made using the RJ45 plug with the pin configuration on the battery plug end provided in Table 5.1.

Table 5.1 Colour Coding and Pin Configuration for CAN Bus UTP Control Cable

RJ45 Pin No.	Standard Ethernet Cable Colour	Wire Function
Pin 1	Orange/White	CAN High
Pin 2	Orange	CAN Low
Pin 3	Green/White	Not connected
Pin 4	Blue	CAN High
Pin 5	Blue/White	CAN Low
Pin 6	Green	Not connected
Pin 7	Brown/White	CAN High
Pin 8	Brown	CAN Low

For most inverters a standard LAN cable will work. For SMA, a special cable is required because of the resistor required on the inverter end of the cable – please refer to the respective inverter brands manuals for their pin configuration or contact Freedom Won for assistance. The special SMA cable is available from Freedom Won.

If hard wired or relay control is required, please contact Freedom Won to discuss your options. A common example or where a relay control from the battery may be desired is to control an alternator with a remote enable function (in boats and RV's).

5.3 CAN Bus Control – Detailed Description

CAN is a widely used communication protocol in systems with many devices that must report their status or send commands to other devices on the same network. The LiTE unit BMS can transmit messages and commands in CAN protocol to provide information to, but more importantly, control external devices. CAN allows great versatility and provides a simple installation because there are only two wires required in this form of communication, namely CAN High and CAN Low. In order for an inverter or charge controller to be controlled by CAN it must first of all be equipped with a CAN interface as well as a suitable method of connecting the CAN wires. Further to this, the LiTE unit BMS must be programmed with a CAN messaging profile that is developed for the inverter or charge controller being used. This profile must be specifically developed for each inverter model or model range. To date, Freedom Won has developed CAN profiles for the following equipment:

- SMA Sunny Island Battery Inverters
- Ingeteam Sun Storage Battery Inverters
- Victron Multiplus and Quattro Battery Inverters and MPPT Controllers via the Color Control GX and Venus system controllers
- Studer
- Imeon
- Solax
- Goodwe
- MLT Drives (2019 models onwards)
- Socomec
- Koyoe
- ATESS (HPS and PCS ranges)
- Sunsynk
- Sunforce/Growatt
- Revo
- Axpert King
- Solis

Freedom Won welcomes any requests to produce BMS CAN profiles for other inverters that are CAN-equipped for BMS interface.

The CAN interface can provide the following functionality to compatible devices:

- i. Charge Current Limit of all LiTE units connected
- ii. Discharge Current Limit of all LiTE units connected
- iii. Actual State of Charge (minimum of all LiTE units connected)
- iv. Actual Battery Temperature (highest of all LiTE units connected)

- v. Actual Voltage
- vi. Actual Current (total of all LiTE units connected)
- vii. Maximum real time charge voltage setpoint
- viii. Battery Name
- ix. Highest Cell Voltage of all LiTE units connected
- x. Lowest Cell Voltage of all LiTE units connected.
- xi. Firmware Version
- xii. Ah capacity of all LiTE units connected
- xiii. Advanced communication between all connected LiTE units

The CAN 2.0 Part A and Part B standard uses the SAE J1939 standard in the LiTE unit. It is necessary to install a 120Ω resistor on each extreme end of the CAN cable (splices do not require a resistor). Most devices operating on CAN have two plugs to connect in and then out again on the CAN Bus. The first and the last device in the chain must have a termination resistor plugged into the spare (second) plug. The LiTE unit resistor plugs are available from the inverter manufacturer and from Freedom Won. Ingeteam has a separate CAN terminal block for bare wires to be inserted from the BMS and these units have an internal resistor fitted into the device. From August 2018, all LiTE models have two CAN plugs for parallel configurations (Figure 4.2) and allowing fitment of the termination resistors on the end of line units. Where one LiTE unit is installed or where it is the end of line CAN device, **the LiTE unit must be fitted with a termination resistor.**

The LiTE unit is supplied with a termination resistor as standard. The other devices must be fitted with the correct termination resistor for that particular brand because the pin configuration may differ from the battery plug.

The third-party device manuals must be referenced for all details regarding connecting the CAN interface. Also refer to the Freedom Won LiTE Home and Business manual for more CAN Bus pin connection information.

Most brands use 500kbps. If 250kbps is required, it is available on LiTE units with a specific profile loaded, which must be requested when ordering the unit or can be loaded during commissioning by your distributor for Freedom Won technical support.

If you did not purchase a CAN Bus cable to suit your inverter you can make your own according to Table 5.2. Fig 5.1 provides the standard colour coding for an ethernet cable (note that there are other variations - cross reference with the Table 5.2. to confirm the correct configuration for the inverter brand).

Fig 5.1 Pin Configuration for standard Type T-568B RJ45 plug



Table 5.2 Pin Configuration for CAN Bus Control Cable for various supported inverters

Inverter Brand	CAN L	CAN H	Comments
Victron (Venus Controllers)	Pin 8 (brown)	Pin 7 (brown/white)	
SMA (Sunny Island)	Pin 5 (blue/white)	Pin 4 (blue)	Bridge Pin 3 and Pin 6 on Inverter end of cable with a 120Ω resistor.
Ingeteam	Open terminal	Open terminal	Labelled on inverter
Imeon	Pin 2 (orange)	Pin 1 (orange/white)	
Solax	Pin 1 (orange/white)	Pin 2 (orange)	This brand requires a special cable to accommodate pin assignment on inverter.
Goodwe	Pin 5 (blue/white)	Pin 4 (blue)	
Sofar	Pin 2 (orange)	Pin 1 (orange/white)	
Struder			The Struder X-Com can be configured to suit one of the options in Table 5.1 using jumpers supplied with the X-Com CAN unit.
MLT Drives	Pin 5 (blue/white)	Pin 4 (blue)	
Socomec			Enquire with Freedom Won
Koyoe			Enquire with Freedom Won
ATESS			Open terminals
Sunsynk	Pin 5 (blue/white)	Pin 4 (blue)	
Sunforce/Growatt	Pin 4 (blue)	Pin 5 (blue/white)	This brand requires a special cable to accommodate pin assignment on inverter.
Revo	Pin 5 (blue/white)	Pin 4 (blue)	
Axpert King			Requires a CAN Bus to RS485 converter that is available from Freedom Won - enquire with Freedom Won Sales.
Solis	Pin 5 (blue/white)	Pin 4 (blue)	

If your inverter is not included in this table, please contact Freedom Won for assistance.

All BMS interfaces above operate at 500kbps baud rate except for Ingeteam, which operates on 250kbps. Please enquire with Freedom Won Technical Support to change the default 500kbps to 250kbps.

5.4 Parallel Configurations

It is permissible to connect multiple LiTE units in parallel provided that the model size used is the same throughout. It is however more cost effective to purchase one larger LiTE model than connecting multiple units in parallel. This type of installation should be reserved for future expansion where it is not feasible to purchase a model large enough upfront for future requirements (financial constraints).

One LiTE unit is programmed as the Master, while the rest of the LiTE units connected to the DC bus are programmed as Slaves. A total of 10 units can be connected in parallel.

For installations using hard wired control to control the inverter or charge controller, the NO and COM dry contact pairs from external relays controlled by the Master LiTE unit via the DB15 plug are used (see further in manual for more information on the dry contact pairs).

The Master LiTE unit must be connected to the slave LiTE units via the CAN Bus using standard LAN cable.

Where CAN Bus is used to control the inverter(s) and charge controller(s), the CAN Bus from any battery (preferably the Master) can be connected to the inverter directly or the system controller, depending on the product brand. **All LiTE Home and Business models are shipped with hardware that enables them to be configured either as a master or as a slave.** This is achieved by providing two RJ45 sockets on the LiTE unit – refer to Figure 5.2. On the master, one socket is used for an end of line (termination) resistor, and the other socket for connecting to the next item of equipment, whether it be a slave battery, an inverter, a solar charge controller, or system controller. On a slave, each socket is used to connect to another item of equipment.

Figure 5.2 Picture Showing 2 x RJ45 Sockets for CAN Bus (DB15 Plug shown here for Analogue and Relay control is not available in new models)



Figure 5.3 CAN Bus Connection Example with Four LiTE units

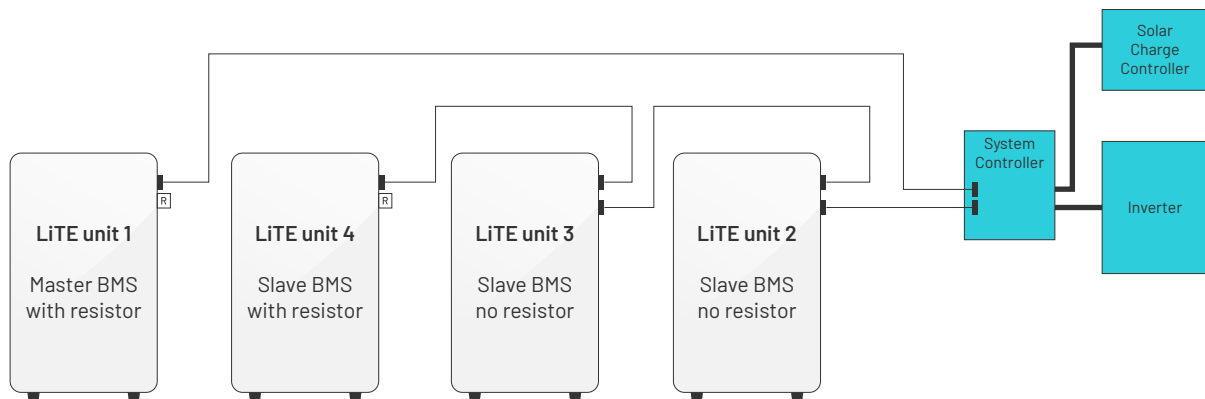

Freedom Won LiTE batteries can configure themselves automatically for master and slave configurations with up to 20 slaves. No programming is required, simply connect the CAN Bus cables and switch on the LiTE unit. The Master will be the first battery that is switched on.

If the master LiTE unit trips, one of the slaves will take over as the master automatically, without any interruption of service.

Freedom Won offers a fair trade-in on LiTE units on the purchase of new units, which is an option for somebody wishing to expand their battery capacity instead of installing parallel units. Please request more details from Freedom Won if this is your upgrade preference.

New units can be placed in parallel with old units up to about 5 years or 1500 cycles, after which it is preferable to trade in for a new larger unit.

6. Programming the LiTE unit

The serial USB plug on the left-hand side of the LiTE unit is used for setting up the profile of the BMS. The USB cable required for connecting the LiTE unit to a computer is supplied with the battery. The computer must have the correct utility software installed. Programming of the BMS is intended only as a function to be performed by Freedom Won and approved distributors and installers. The manual on how to operate the BMS along with the utility is available from Freedom Won. Write access to the BMS profile is password protected, however users and owners may request read-only access.

7. Switching on the LiTE unit

The LiTE unit is fitted with an "ON" button. Press this button for at least 5 seconds to switch on the BMS inside the battery. Once the BMS has been energised you will observe the SoC display come to life with the SoC level shown. Confirm at this stage that the error light is not illuminated. If it is, contact Freedom Won. If the Reduced Power light is illuminated, do not be concerned, it should turn off automatically after the battery has been in operation for a few hours.

Once the BMS has been energised, the main breaker may be switched on by pushing the breaker upwards. Ensure beforehand that you have secured the DC cables to their proper locations and that the rest of the system is ready to receive battery voltage.

Note: On some inverters there is a large inrush current when switching on the DC supply. It is important in these instances to pre-charge the DC bus. With Victron, this can be achieved by switching on the PV to the MPPT's to allow them to apply voltage to the DC bus before closing the battery breaker. If this option is not available, you can switch on the AC input power to the Victron inverter as this allows the inverter to place voltage on the DC bus. If you are using inverters that cannot do this, you will need to use a pre-charge resistor.

To switch off the DC output from the LiTE unit, pull down the breaker. To switch off the power to the BMS, press the "OFF" button situated to the right of the "ON" button. This will also trip the breaker if it is still on at the time. The LiTE unit must be switched off fully when not in use to prevent self-discharge.

Fig 5.1 "ON" and "OFF" Buttons



8. Settings Required for Configuring Inverters and Charge Controllers

The maximum and continuous discharge currents for the respective models are provided in Table 2.1. For charge current settings refer to the charge current limit. An average recommended charge current is one third of the continuous rating of the battery. The combination of the mains charger and the Solar Charge Controller (SCC) must not exceed the maximum continuous charge current; this must be specifically checked.

The voltage settings for the Freedom Won LiTE range of nominally 52V batteries when operating in a system where the BMS can control the external are as follows:

- Minimum (cut off) – 47V (the LiTE unit should never reach this low voltage but it is good to have this set as a redundancy protection measure.
- Low Battery Voltage Warning (if applicable, often used to revert to grid power in increased self-consumption applications because it approximates 30% SoC) – 51V
- Max Charge Voltage – 55.8V (Bulk, Absorption and Float are all set to this value)

If the BMS is not able to control the external devices with CAN Bus, then the voltages must be set at slightly conservative values:

- Minimum (cut off) – 49V
- Low Battery Voltage Warning (or revert to grid) – 51V
- Max Charge Voltage – 55.6V

A voltage can also be set according to user requirements on the inverter depending on how much battery power may be used before grid power will take over from the battery (if it is available). It should be determined based on how much battery SoC is desired at all times as a minimum to ensure adequate capacity to handle a grid outage or load shedding. The daily cycling depth is also a consideration for the user in terms of battery service life.

The recommended voltage for forcing the inverter back to grid power in a self-consumption setup is:

- 52.0V for approximately 60% DoD
- 51.0V for approximately 70% DoD

In non-CAN Bus systems fitted with DC solar charge controllers (SCC) the AC charger should stop charging at 53.5V to allow the remainder of the charge to be performed by the SCC.

The SCC voltage set point would be set to 55.8V if BMS control is functional and 55.6V without BMS control. Note that it may be necessary to use a slightly lower voltage initially if the cells have not had sufficient balancing time – if the battery trips prior to reaching 55.5V it is because one cell has reached its maximum too early. Try starting with 54.5V and then after several days of balancing increasing it to 55.5V (this is a rare scenario). For Victron and other fully integrated systems, the LiTE unit controls this voltage maximum automatically.

Note: For applications where voltages are measured during high current discharge it might be necessary to adjust slightly the values given above to cater for cell internal resistance.

Note: For systems with an interface between the battery and the rest of the system it is advisable to use SoC for controlling charge and discharge algorithms as this is the only accurate method – using voltage as described above is only an approximation.

9. Accessories

Freedom Won offers the following accessories:

Table 7.1 List of Accessories

Item	Description
120Ω Termination Resistor - RJ45	For plugging into the second CAN port for an end of line Battery (usually these are supplied with CAN Enabled inverters and hence it is generally not necessary to purchase from Freedom Won.
Eye Bolt M12	Required for lifting 5/4 and 20/16 models using the hard point on top of the unit - for installation onto the wall.
Gantry - see price list for options	Used for lifting LiTE units onto wall mount bolts as well as lifting the floor standing models into the upright position. Available with various width gantries (narrower to suit contracted installations). Fitted with 3 500kg electric winch, includes lithium battery and built-in charger. Can be disassembled and reassembled in minutes for easy transportation.
CAN Bus Cables	For various inverters requiring non-standard cables.

10. Typical Installations

Some examples of how to integrate Freedom Won LiTE unit into battery backup and solar installations using Victron equipment are provided below.

11. Victron CAN Interface Systems (example with DC Charge Controllers)

All Victron systems must include the Color Control, Venus controller, Octo GX or Maxi GX. Note that if CAN Bus MPPT's are used with a system containing more than one LiTE unit, it is necessary to use a Victron controller with a dual CAN Bus, which precludes the abovementioned Color Control. The Victron CAN Bus MPPT's will use CAN Bus 1 and the LiTE unit will use CAN Bus 2. For a single LiTE unit with CAN Bus MPPT's, the MPPT's and the LiTE unit can operate on the same CAN Bus and therefore the Color Control can be used. For a system using only Ve Direct MPPT's the LiTE unit will use one CAN Bus and hence the Color Control can be used.

Figure 5.1 below provides a schematic of a PV solution with battery backup and a connection to the grid.

Figure 5.1 Example of a Grid Connected PV System with Battery Backup using a Freedom Won LiTE unit, Victron Multiplus or Quattro Inverter Charger and a Smart Solar Ve. Direct Charge Controller.

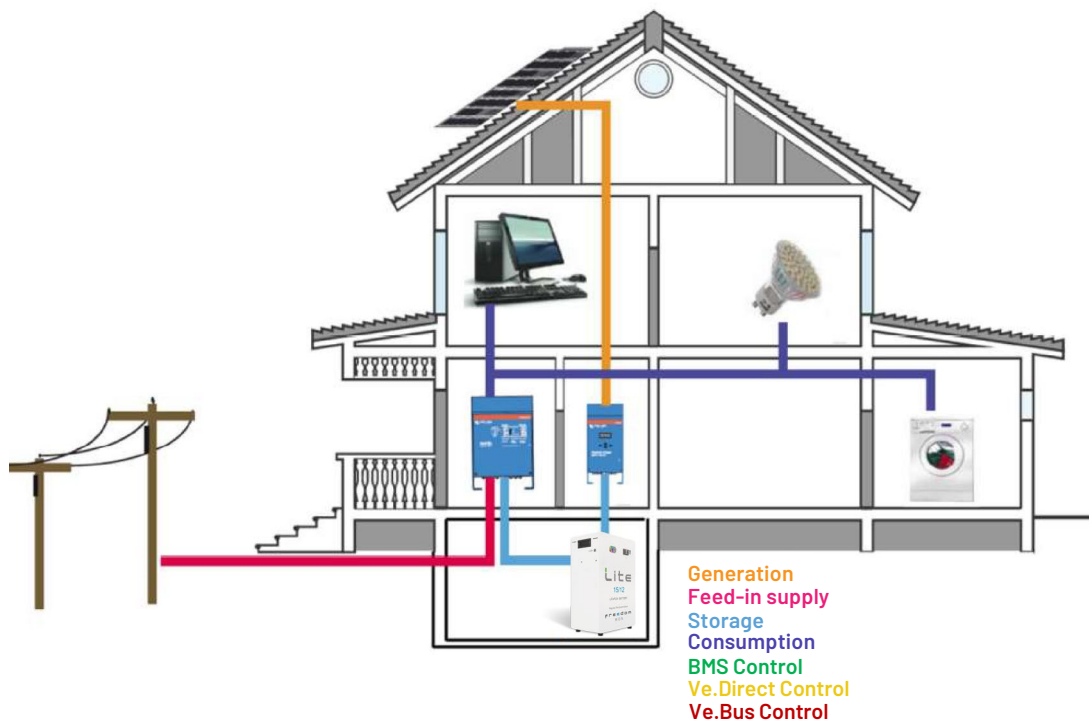

In Figure 5.1 the grid is connected to the input AC 1 terminals of the Multiplus or Quattro battery inverter (with a Quattro the AC 2 input can be used to connect a generator). The AC 1 output is connected to the house circuits that require battery backup (with a Quattro the AC 2 output can be connected to non-essential loads for automatic load

shedding in a grid outage). The 48V DC connections on LiTE units are connected to both the inverter and the solar charge controller (SCC). There is also a BMS CAN Bus control connection between the LiTE unit and the Color Control system controller (a Venus controller can also be used). Multiple inverter and SCC units can be installed in parallel and also in three phase configuration.

Note that to comply with the legislation of your country it may be a requirement to include an appropriate anti-islanding device between the grid supply and the inverter. The Victron Multiplus and Quattro inverters do have a transfer switch that disconnects the grid from back feeding when the grid power is down, but may not comply with local legislation. The Multiplus II models are however approved in most countries for anti-islanding as they contain upgraded anti-islanding equipment.

The inverter will within 20ms transfer power in the house to battery backup if the grid power fails. This is sufficiently fast to prevent appliances from being affected. The unit can also exclude most voltages spikes higher than a user adjustable value within a 20ms period.

Once transferred to battery power the inverter will continue to operate until the BMS instructs it to stop on CAN Bus. This should only occur if the LiTE unit has dropped to 10% SoC (90% DoD). The inverter will then not function off battery until either the solar charge controller has recharged the battery to at least 20% SoC and will thereafter continue to operate provided that the SoC remains above 10%. When grid power is restored the inverter will immediately revert back to the grid source. The system design should be based on assuming only 70% to 80% DoD will be used on a routine basis with 90% DoD being the absolute cut-off for occasional scenarios.

The Victron Multiplus and Quattro inverters and the Blue Solar charge controllers are connected to the Color Control or Venus. For grid connected systems the ESS assistant should be installed on the Multiplus/Quattro. For off grid systems no assistants are required on the Color Controller/Venus.

It is also possible to configure the Victron inverter to feed energy to the grid if the battery voltage or SoC is above a defined value. This must be set up properly using the configuration software and the connection must be authorised by the utility and any other applicable body in your country.

Note that the above diagram is a simplification. In many household installations the inverter may not be intended to run heavy consumers such as electric geysers, stoves and household heating. These are often connected to the grid directly and do not pass through the inverter. They could be connected to AC 2 output of the inverter for internal load shedding or to the AC input with a grid meter for feeding to loads connected in the utility side.

It is also necessary to ensure that the AC output of the inverter is fed to either a separate Distribution Board (DB) or to a section of the main DB that is physically apart from the incoming utility supply and the other breakers that are fed from the utility directly.

This is to ensure that it is practical to clearly label the inverter output section of the DB so that it is clearly evident that this section will remain live despite the utility incomer being off. Observe the relevant regulations.

Several important settings must be correctly configured in the Color Control, Multiplus/Quattro, and charge controller. The latest firmware versions must also be installed in each case. Please refer to Victron manuals or contact Freedom Won for assistance with this.

Guidelines at this link will also be useful:

https://www.victronenergy.com/live/battery_compatibility:freedomwon

12. Victron Inverter and Grid Tie Inverter

The main alternative to installing a DC charge controller is shown in Figure 8.2. This system incorporates a grid tie inverter (GTI) or PV inverter on the consumption side of the battery inverter.

Note: It is also possible to install a GTI on the grid side of the battery inverter but this option is not recommended when connected to an unreliable grid because the PV potential cannot be utilized during an outage, as the GTI will shut down without the grid power being present.

Figure 5.2 Installation Example using a Victron Battery Inverter and a Grid Tie Inverter with a LiTE Home 15/12.



In this installation the LiTE unit controls the system through the Color Control using CAN Bus. The Color Control in turn controls the PV inverter and the Multiplus/Quattro.

The Multiplus can control most PV inverters using frequency shift on the AC output. Compatible GTI's will measure this variation in frequency and adjust the power put into the consumption side AC bus accordingly. This is only recommended for off-grid systems or for grid-connected systems where grid feed in is allowed. For grid-connected systems where grid feed in is allowed. For grid-connected systems where feed in is not allowed it is preferable to use the Fronius models because additional control can be used from the Color Control making for a more robust system. The battery inverter will determine when to 'throttle' back the GTI based on its own power (current) measurements. If the combination of the house consumption and the ability for the inverter to place charge into the battery is not sufficient to consume all the power the GTI can deliver there are two options for the battery inverter. If it is set up for feeding back to the grid, it can do so, which would mean that the GTI need not be 'throttled' back. If it is not set up for feeding back to the grid and the voltage of the LiTE unit has reached its maximum voltage, it will reduce the power delivery of the GTI to that which is equivalent to the consumption in the house at that time.

For grid-connected systems ESS should be configured on the Victron system and the necessary additional assistants and settings must be added for the PV inverter.

For household systems this option using a GTI is typically more expensive than using a DC SCC but it is useful if a system already exists using a GTI, to which a battery inverter and LiTE unit is to be added, because the GTI can usually be retained.

GTI's do typically have a much higher maximum PV voltage input, which reduces the amount of parallel connections required on the panels and thus makes installation easier for larger systems.

NOTE: When commissioning a system like this using Fronius PV inverters, be certain to set up the Fronius inverter correctly with the MODBUS TCP control interface as the first priority. Refer to the Fronius manual for more information - it is very important.

13. System and Product Variations

The systems above are only examples of how to incorporate a LiTE unit into a total solution based on Victron products.

Other inverter brands can be incorporated into the same types of configurations so long as they have the right interfacing requirements, such as SMA Sunny Island battery inverter incorporated with a SMA Sunny Boy GTI. Hybrid inverters that essentially contain both the battery inverter/charger function as well as the SCC in one unit can also be used e.g. Sunsynk and Imeon.

For help with connecting to, and configuring, the list of supported inverters please contact Freedom Won Technical Support.

14. Warranty and Repair

The LiTE unit is sealed with a tamper proof warranty seal. It may not be opened by anyone other than Freedom Won and installers or repairers that have been explicitly approved by Freedom Won. The warranty on the unit will be void if the seal is damaged or missing.

If the LiTE unit indicates an internal problem, please contact Freedom Won or the installer that installed the system. Freedom Won will arrange that it is inspected and repaired.

The warranty will not cover damage to the control wiring resulting from draw of excessive current or any damage resulting from lightning. Damage caused by physical means to the battery housing, external and internal fittings, such as impact with other objects, or being dropped, is not covered by the warranty.

The standard warranty period is 10 years or 4 000 cycles at an average of 80% DoD, whichever should first occur. The battery is required to provide at least 70% of its new capacity at the end of this period or cycle count. The BMS records the number of cycles used. If you suspect that your LiTE unit is delivering substantially below its minimum performance, please contact Freedom Won for an investigation. If the unit is found to be underperforming it will be serviced such that the minimum performance guarantee is again restored. Freedom Won may arrange for an on-site service or for collection of the unit for servicing at our facility. This will be mostly determined by the geographic location, ease of access to or removal of the unit, and size of the unit.

For more detailed warranty information please contact Freedom Won.

Note: the above warranty statements apply to LiTE units sold by Freedom Won on or after 1 September 2019 only. For LiTE units sold by Freedom Won prior please contact Freedom Won for the correct documentation.

15. Expected Product Life

LiTE models are designed for optimal life cycle cost, which is a fraction of any other battery technology available on the market, in particular from 25% to 35% of the lifecycle cost of the range of lead acid and associated variants on the market. Please contact Freedom Won if you would like more detailed information for comparison with lead acid batteries than what is available on our website.

LiTE models are expected to operate for about 16 years in a daily cycling scenario for more than 5500 cycles with an average of 80% DoD. For occasional cycling applications (for typical load shedding for instance, as is experienced in some countries) the service life expected is 20 years or more.

For applications where the cost per kWh delivered by the battery during its lifetime is of prime importance (i.e. maximum return on investment) we recommend that the battery be sized for an average cycle discharge of 50-60% DoD. In a daily cycling scenario such as for optimal solar self-consumption and off grid systems the expected

service life is then 20 years or more than 7500 cycles. The defined end of life in this instance occurs when the battery capacity falls to 60% of the new capacity.

16. Troubleshooting Guide

Most issues with the LiTE unit can be resolved using the guide below. If a problem cannot be resolved after referencing this table please contact Freedom Won or your approved Freedom Won supplier.

Table 14.1 Troubleshooting Guide (applicable to units with On and OFF buttons)

No	Problem Description	Cause/Solution
1	Eye bolts do not screw into hard point on top of LiTE units	Check that you have the correct eye bolt with the correct thread pitch - M12 x 1,75
2	The rawl bolt head does not fit into the hole on the back of LiTE units (wall mounted models)	Check that you are using the correct size Rawl Bolt as specified in this manual and that you have after positively tightening the internal gripping collar turned the bolt out again so that there is about 5mm of the bolt shank exposed so that the back plate can fit easily behind the bolt head. If the wall is uneven it may be necessary to turn the bolt head out a little more. Do not turn it so far out that there is less than the full thread length engaging on the internal locking collar.
3	The LiTE models have no voltage on the main output cables	Check that you have switched on the main breaker switch. Note – only turn this on once you are satisfied that you have completed the installation and that there are no DC or control wires that can short out or touch ground or other wires. Also ensure that you are ready to accept AC voltage onto the inverter output before switching this breaker on. Also confirm that you have energised the BMS first by pressing the “ON” button for 3 seconds and as evidenced by the lights on the SoC display. If voltage is still not present with the breaker switched on it is possible the breaker has been damaged – please contact Freedom Won.
4	The BMS (indicated by battery SoC display lighting up) does not stay on after the ON button is pressed	<ol style="list-style-type: none"> 1. Error on the BMS. Check whether the red error light is illuminated on the SOC display when the ON button is held in. You can try to reset the error by pressing the RESET button for about 2 seconds and release. This should clear the error and allow the BMS to stay on after releasing the ON button. 2. Battery has been discharged to critically low level – remove all potential loads from the battery and switch off the inverter(s). Then try to switch on the BMS. Battery has been charged to critically high voltage level – 3. usually leaving the battery for an hour will allow the cell levels to drop down within the acceptable levels and allow the BMS to be switched on again. 4. If the BMS still does not switch on, please contact Freedom Won or Authorised Distributor.

<p>5</p>	<p>The main breaker switch keeps tripping each time I attempt to switch it on</p>	<p>There are several potential causes:</p> <ol style="list-style-type: none"> 1. The BMS has not been switched on. The ON button must be pressed for 5 seconds. On release the SoC Display must remain illuminated. 2. High inrush current on certain inverters – First preference is to pre charge the DC bus by switching on the solar charge controllers if present and in daytime. If this is not possible switch on the AC feed into the inverter and switch on the inverter. Some makes will then pre-charge the DC bus. You can also use a pre-charge resistor for this. If this does not work after the second attempt investigate the other options. 3. Short circuit on the DC Bus or faulty inverter or MPPT causing high currents. 4. In a system with multiple LiTE units in parallel, the reason could be that the unit you are trying to switch on is at a different voltage to the others – the voltages must be similar (within 1V of each other) on all batteries when switching them onto a common DC bus. <p>If none of the above solve the problem, you will need to contact Freedom Won or your authorised installer for assistance with this issue.</p> <p>It will be necessary to establish the reason for the error before continuing with normal operation of the system. Repeated tripping is damaging for the breaker.</p>
<p>6</p>	<p>After resetting the BMS the main breaker still will not stay up</p>	<p>The is most likely because the battery is fully discharged and the BMS is protecting the cells from further discharge. Ensure that there is no chance of load being applied to the battery by isolating the AC output from the inverter. Ensure that the AC input to the inverter is live so that the charger may begin charging the battery after you switch it on. Alternatively, an MPPT can be used for this immediate charge if there is sunshine at the time. This charge should increase the battery voltage to prevent further tripping. This problem should not occur if the inverter control is working properly.</p> <p>If this does not work, it is because the battery has been discharged too deeply and will need to be reset remotely by Freedom Won by accessing your Windows PC connected to the battery. The PC must have TeamViewer installed and you will need the RS232 adaptor to connect the PC to the battery. Please contact Freedom Won.</p>

7	I have switched off the main battery breaker switch to prevent discharge of the battery but the SoC display lights are still on	The BMS and SoC display receive power directly from the battery and therefore the "OFF" Button must be pressed to switch off the internal electronics.
8	The inverter will not come on even though the inverter switch is selected to 'on'	<p>The enable command may not be coming from the BMS or may not be properly connected to the inverter or the inverter may not be properly configured to deal with the enable command.</p> <p>If you are running on a CAN Bus control with a compatible inverter and you are not observing the correct enable response from the inverter check that the CAN High and CAN Low wires are connected properly (ensure that you have the High and Low the right way around and that you have connected the two end of line 120Ω resistor in the applicable places. If this is not the problem then you need to confirm that you have the right CAN profile programmed onto the BMS for the inverter in use (baud rate or CAN messages may be for another inverter brand) or that you have configured the inverter or system controller correctly. Check that your CAN Cable is properly made up on the pin configuration and that the terminations are good. Contact Freedom Won or your Authorised Distributor for assistance.</p>
9	The charger will not come on even though there is power on the AC input of the inverter and the charger is activated in the inverter settings	The battery might be full. Try discharging the battery for a while and observe if the charger then comes on. If not, then the fault finding process is similar to above.
10	The error light keeps illuminating after each reset	If the battery voltage is within limits this should not ordinarily occur. Contact Freedom Won or an approved installer for assistance with determining the problem. If the main breaker does not trip it is not a critical error and you may continue using the battery while you make contact for assistance.
11	The pack voltage is within limits, but the main breaker still trips seemingly at random	This could be caused by many things but is most likely because the current draw is exceeding the battery current limit setting. Measure the current with a tong tester while drawing your maximum typical load to determine if you are exceeding the rated current for the respective LiTE model. If it is not the current causing the trip it could be a weak cell or extreme temperature of the surroundings. Both are unlikely. If the problem persists, contact Freedom Won.

