

## FixE

### The safe fastening system for Eternit roofs

- Swift assembly from above
- Program-generated structural verifications
- Components made of aluminium / high-grade steel
- For roof-parallel applications and for elevations
- Special EPDM-sealing cap
- Can even be used with thin purlin thicknesses!

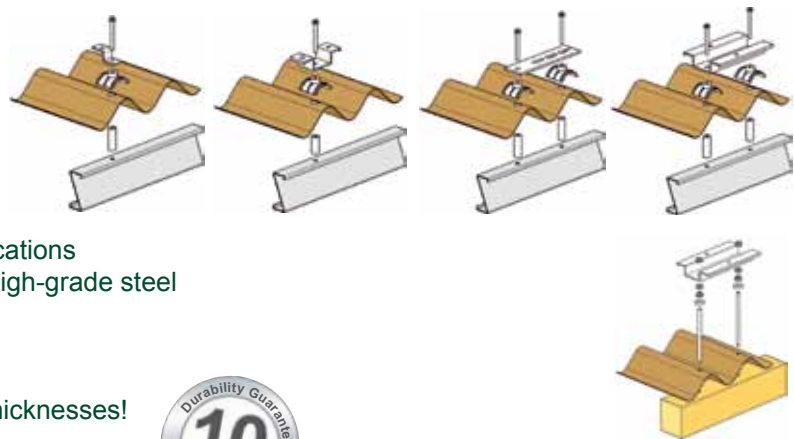

➔ Ordering exclusively using the checklist

**Schletter FixE** has been designed especially for a safe fastening of solar plants and thermal plants on Eternit roofs. Usual fastening systems often cannot be structurally verified by 100% and also load the corrugated plates in an impermissible manner, which can result in breakage and leaks. Due to the utilization of distance tubes, the fastening system FixE transfers the fastening forces and also possible bending moments safely into the substructure. Thus, a sufficient durability can also be safeguarded in difficult cases and also with sheet metal purlins. A specially shaped gasket made of UV-resistant EPDM-rubber serves as a sealing.

### Combination

**FixE** is usually installed with the CompactVario system or the CompactGrid system (please see the accordant product sheets). Thus, all kinds of elevation variants are possible on purlin roofs. For bridging the purlin distances, a complete series of double-grooved rails with different spans is available.

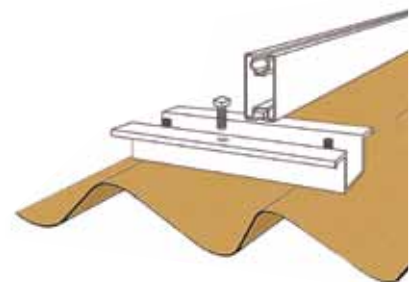

### Different designs

**FixE fasteners** are available as single and twin connectors (see the pictures above). The single fastener without Z-angle can be used for direct fastenings of supports respectively CompactDirect supports.

The application of a mounting claw that is clamped onto the FixE cap profiles makes the mounting of diagonal mounting beams even more convenient - the mounting claw can also be used with one-layer mounting (bearing rail ridge-eaves) in order to safeguard position permanence of the horizontal beams at the defined fastening points. (On the picture on the right, you can see an inclined view from below of a diagonal elevation with a FixE size 3 and a DN1-mounting beam.)

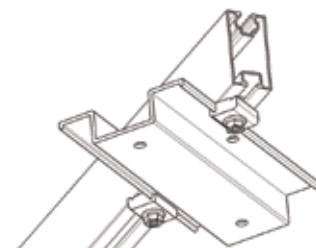

### Modifications and structural analysis

On the basis of a check list, the supporting elements are adapted to the roof covering, the corresponding screws are selected and the length of the distance tubes is determined.

The structural dimensioning of the complete construction (roof connections, support plates, elevation) is carried out using a user-friendly structural analysis program.

### Application information

For the assembly of the FixE components and especially the distance tube, drillings with a bigger diameter have to be drilled into the roof cladding. This is not a problem with state of the art fibre-cement plates, but according to the Ordinance on Hazardous Substances, plates made of asbestos cement may only be drilled by expert companies that have an accordant certification. Only approved slow-turning tools with caption devices may be used.

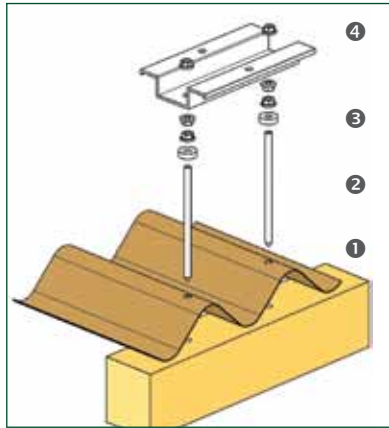

FixE on timber purlins

**1 Pre-drill the fastening points**

	Crown	Timber purlin
with hanger bolts M10	15mm	7.0mm
with hanger bolts M12	16mm	8.5mm

**2 Fastening of the hanger bolts**

	Regular thread reach
with hanger bolts M10	60mm
with hanger bolts M12	100mm

**3 Fasten the sealing rubber with the flange nuts. The sealing rubber must be slightly pressed**



EPDM gasket

**4 Put on the mounting plate according to the distances between the crowns and fasten them with flange nuts.**

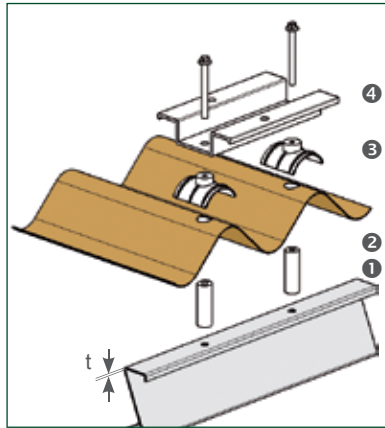

FixE on steel purlins

**1 Pre-drill the fastening points**

with tube	Crown	Steel purlin	Drill
16	17mm	t up to 4mm	6.8mm
20	21mm	t up to 11mm	7.0mm
		t from 11mm	7.2mm

**2 Insert the distance tubes**

**3 Put on the sealing cap**



EPDM-sealing cap

**4 Put on the cap profile and fasten it with screws with a thread thickness of 8mm**

Fasten the screws using a moderate torque  
The sealing rubber must be slightly pressed

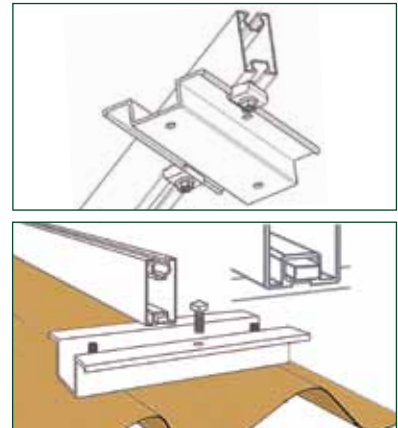

Mounting of the load-bearing rails

Please find more information in our system-specific mounting instructions, for example in the

➔ CompactVario mounting instruction

**Please note:**

For this fastening solution, we recommend the following thread sealing: **195000-032** screw securing 50ml

➔ Product sheet thread sealing

**Technical data**

<b>Material</b>	Screws: High-grade steel 1.4301, 8mm for steel purlins; Hanger bolts M10 or M12 for wooden purlins. Supporting elements: Aluminum cap profiles; Distance tubes: Aluminium diameter 20 mm / 0.79 inch (only with steel purlins); Sealing: Concentric UV-resistant EPDM gasket for steel purlins, special sealing gasket respectively corrugated roof rubber for wooden purlins; UV-resistant EPDM form piece as a sealing sleeve;
<b>Structural analysis</b>	Structural analysis in accordance with current national standards (in Germany DIN1055 and EC1). a) Roof-parallel mounting: Tables specifying the number of fastening spots b) Elevations: Structural analysis project planning program CompactVario

System prices can be calculated quickly and easily with our auto-calculator!

\*acc. to the respective product sheet and our General Terms and Conditions of Sale and Supply(www.schletter.de/AGB) · Subject to modifications and also technical modifications.