

Installation Manual

25KW-63Amp AC Protection Board for Grid Tied Solar Inverter Systems

*Part Number:
ACDB-63A-63A-1-1*



Introduction.

In accordance with local and international standards, the protection of equipment and people is required to ensure the safe operation and maintenance of electrical products, appliances or devices.

This AC protection is designed for both the protection and safe operation of the Solar inverter it is designed for.



WARNING: Installation of this AC Protection board to be by qualified personnel only



WARNING: Electricity is dangerous- Please ensure the correct tools and personal protective equipment is used when Installing, Wiring or Operating Electrical Equipment



WARNING: All terminations should be checked for any potential loose connections that may have occurred as a result of transport activities and vibration. Loose connection may cause hot connections that could lead to damage and/ or fire



WARNING: Although all precautionary measures are taken into account during manufacturing it is the responsibility of the installer of this product to ensure that it installed in accordance with the relevant bylaws applicable to embedded generation systems and low voltage electrical equipment



WARNING: This Electrical board has an IP65 rating, and is suitable for outdoor mounting.

Installation should where possible be done out of direct sunlight, direct water spray, and rain. If this is not possible, it is recommended the board is to be fitted with a suitable rain and sun canopy to protect from direct sunlight and rain or spray.



WARNING: In accordance with local bylaws and installation and wiring of premises, this board should be installed in such a manner that maintenance and inspection can be carried out without the use of special tools or equipment, such as ladders and scaffolding.

Description

This AC Board is designed for the connection and protection of 25KW grid connected inverters.

The board is also equipped with a Type 1 & 2 AC Surge protection device intended for the protection of the inverters and other equipment from surges originating from the utility supply side of the installation.

Two variations of this product are available, as per the ordering code below.

Ordering Code:

ACDB-63A-63A-1-1

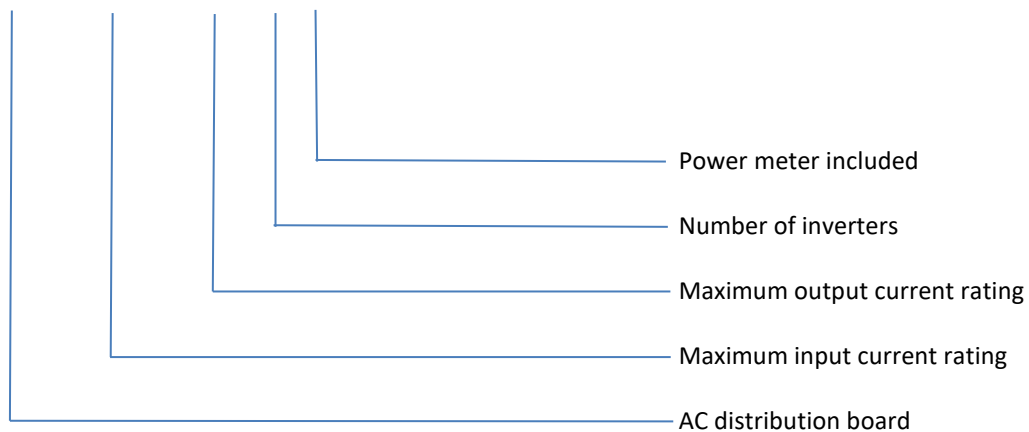

Mounting:

The board is designed to be Wall mounted. Please ensure that the chosen surface is suitable in order to support the weight of the board, for example brick wall.

It recommended that the board is mounted vertically.

Please ensure enough clearance area below the board to facilitate the incoming and outgoing cables can be installed in such a way to maintain the cable manufacturers recommended bending radius. See Fig 1.

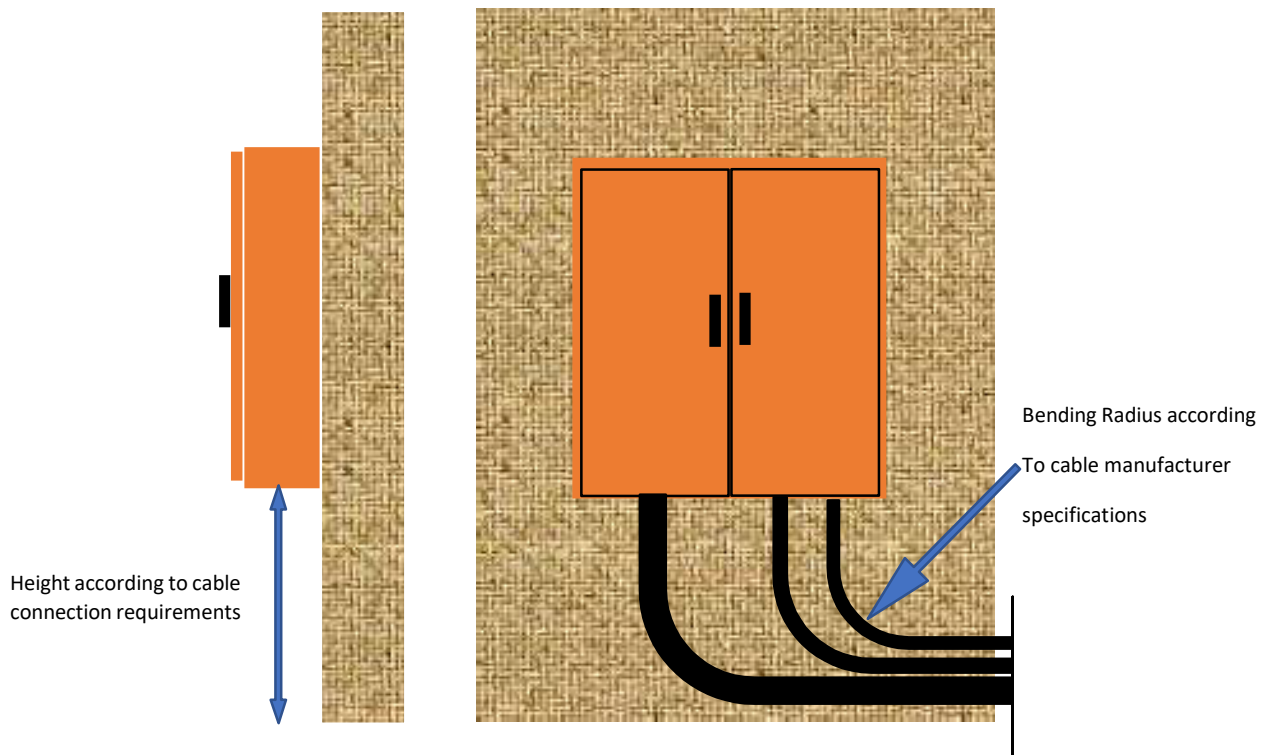
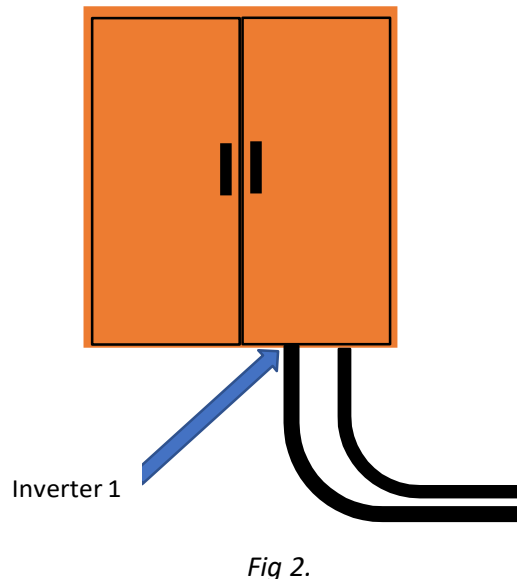

Fig 1.

Connecting the inverters:

The inverter is connected to its own circuit breaker, and will be protected individually.

Recommended cable entry point is from the bottom of the enclosure. See Fig 2.



Note: Please use the appropriate cable gland for the cable type that is used for the installation.

For SWA cable: Steel wire armoured gland with cone

For Flexible cable ie. H07-RNF- suitably selected IP 65 Compression gland

In all instances ensure the use of the matching shroud to protect the gland and assist with ingress protection. See Fig 3,3a, and 4 below.

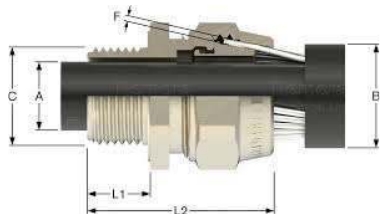

Fig 3



Fig 3a



Fig 4

Connect Inverter feed cable phase conductors (L1-Red, L2-White, L3 Blue) to the Busbar as per Fig 5 below

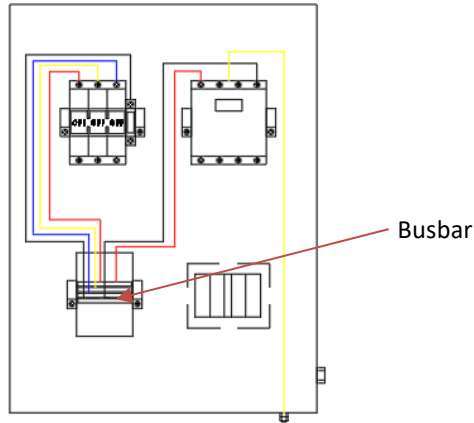

Fig 5

The Neutral Conductor for each incoming inverter feed cable should be connected directly to the Neutral Busbar on the Busbar block. Please see figure 6 Below

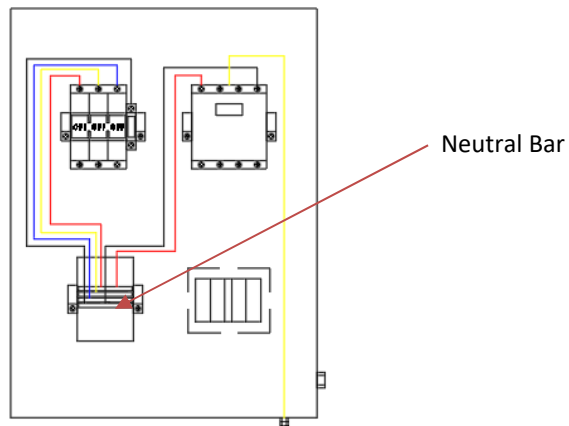

Fig 6

- Recommended Inverter cable conductor size is 70mm² per core for the phase conductors
- Please use the correct crimp or ring logs for the appropriate connections
- Ensure all connections are tightened to the correct torque
- All metal parts of the installation shall be bonded with an earth conductor suitably sized as per the requirements
- Conduct an insulation test prior to final connection of all connected cables

Main output section connection:

The main out section houses the Main Output circuit breaker of the system.

It is critical that all connections are checked before power is applied to any parts.

The main cable is connected to Q0 as per fig 8 below.

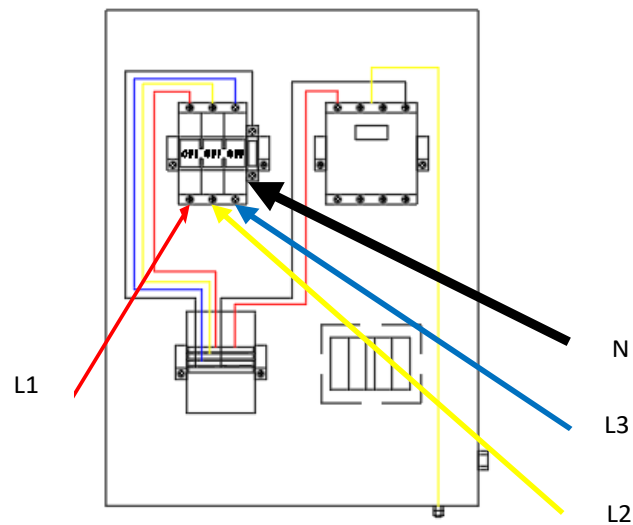

Fig 8

- Recommended main cable conductor size is 70mm² per core for the phase conductors
- Please use the correct crimp or ring logs for the appropriate connections
- Ensure all connections are tightened to the correct torque
- All metal parts of the installation shall be bonded with an earth conductor suitably sized as per the requirements
- Conduct an insulation test prior to final connection of all connected cables

Power Quality meter

The ACDB meter version with Power Quality meter has been pre-configured for the appropriate CT current setting, no further setting is required by the user

The power quality meter is used as a tool to assess the performance of the PV plant.

All values are there in relation to the production characteristics of the PV plant including the power factor and harmonic values

Other values include current per phase and total kWh energy delivered by the plant



WARNING: Please ensure all connections including factory connections are checked as it could have become loose due to transport and handling.

The ACDB is supplied with the appropriate marking and rating labels, please ensure any additional warning or rating information is added to the system as may be required due to site specific conditions and location.



SAFETY FIRST- Equipment to be inspected and tested by suitably Qualified person