

Instructions for Fast Installation Hybrid Series

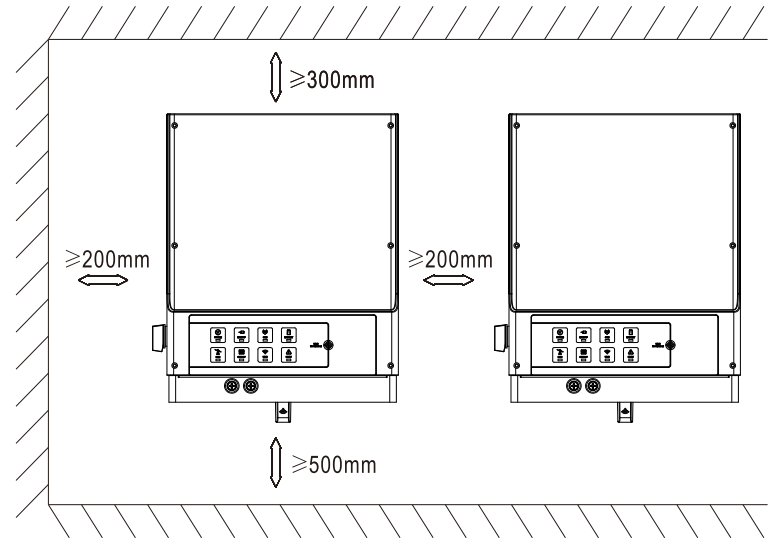

Warning: All fasteners must be locked tight. Otherwise water may flow in, resulting in machine failure. In such case warranty shall not be provided.

A



Installation space

B

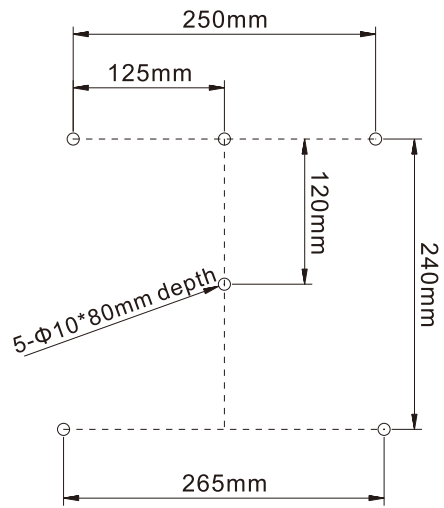

Dimensions for Drilling holes

C

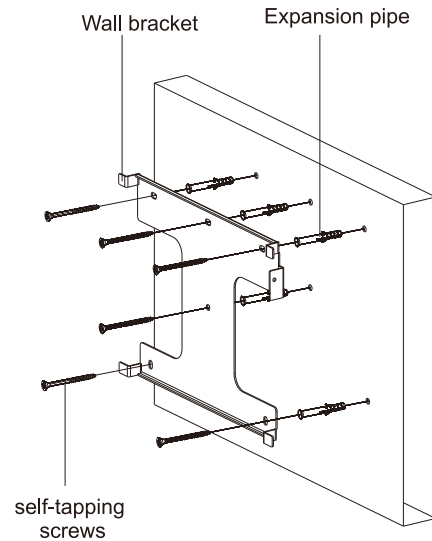

Fix the Wall bracket

D

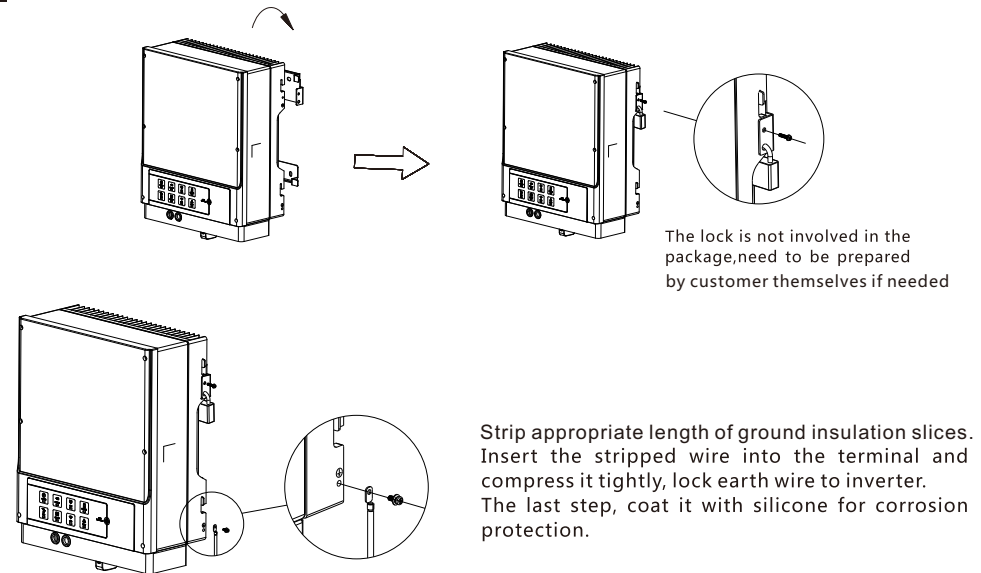

The lock is not involved in the package, need to be prepared by customer themselves if needed

Strip appropriate length of ground insulation slices. Insert the stripped wire into the terminal and compress it tightly, lock earth wire to inverter. The last step, coat it with silicone for corrosion protection.

Installation

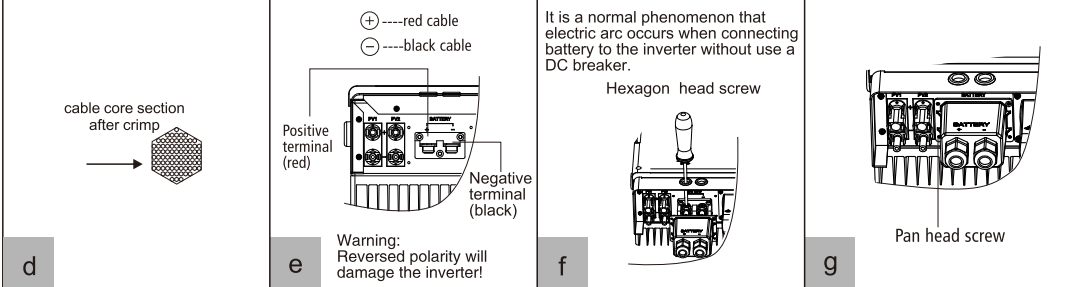
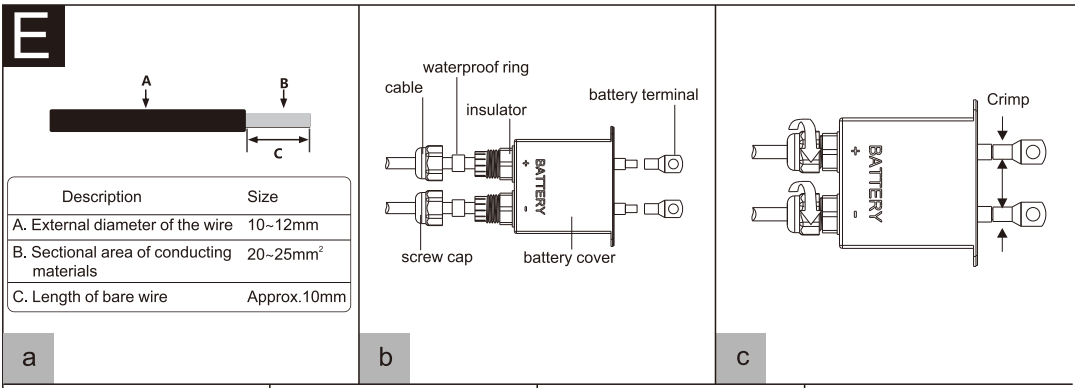

Battery wire assembly and connection

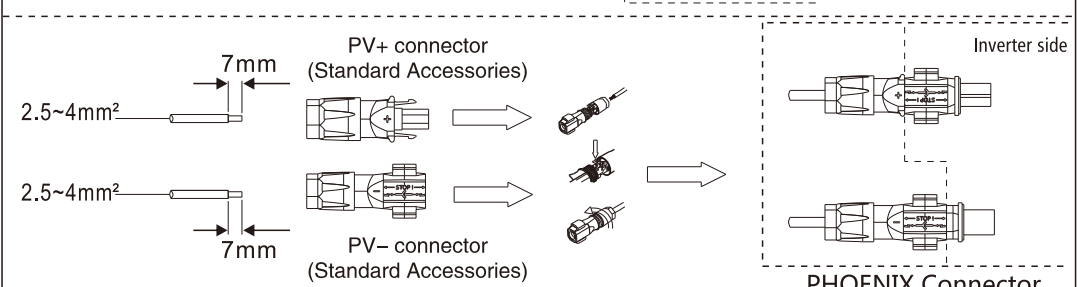
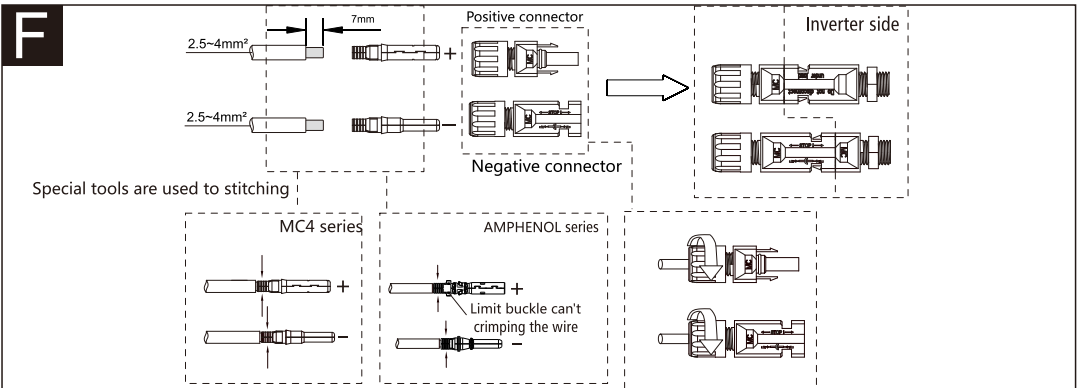

DC wire assembly and connection

DC Cable should be use dedicated PV cable(Suggest using 4mm² PV1-F wire)

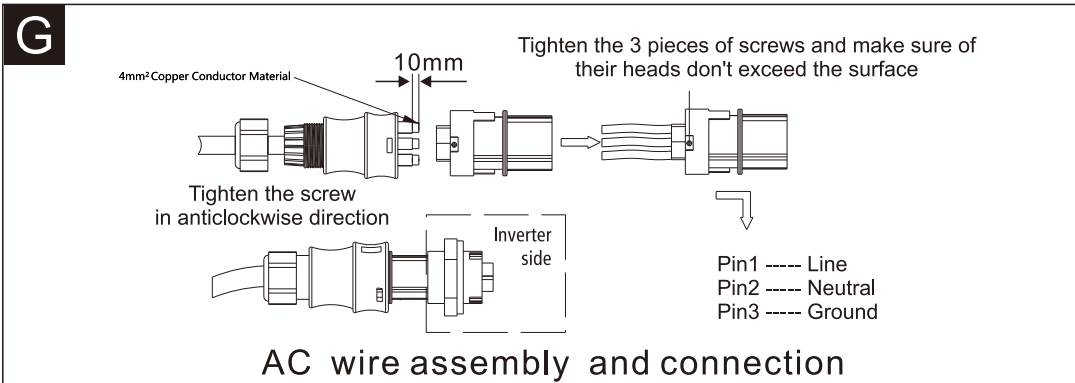

AC wire assembly and connection

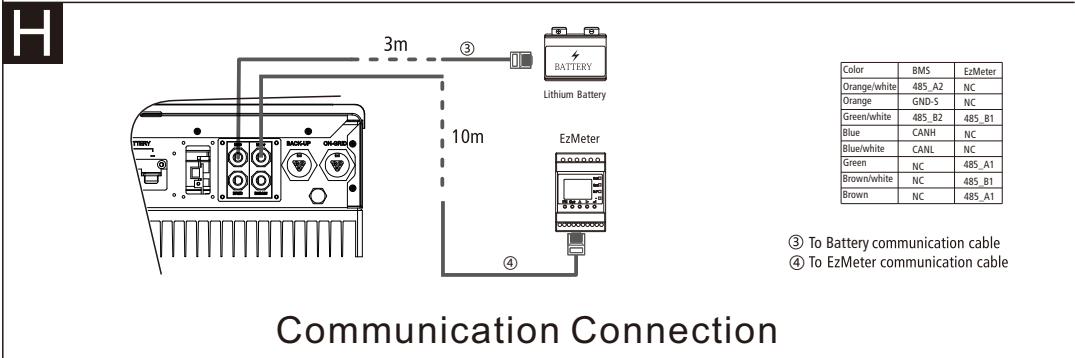

Communication Connection

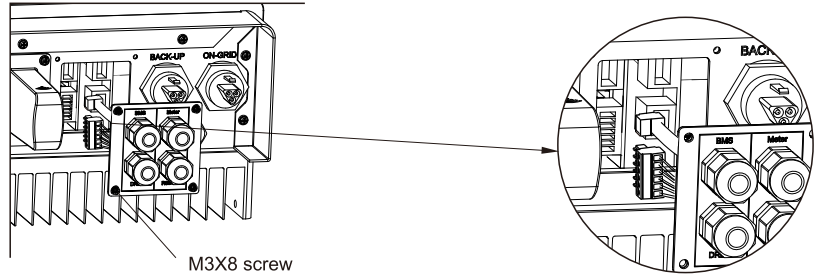
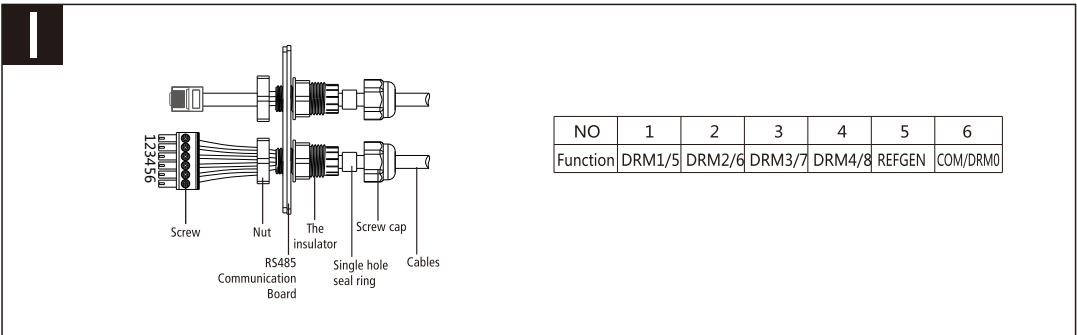

DRED cable assembly

DRED connection is only available for Australia and New Zealand