

Rapid¹⁶ module clamp

INSTALLATION GUIDE



GENERAL INSTRUCTIONS

TOOLS NEEDED

Screwdriver with bit holder Bit TX drive T40

FASTENING TORQUE

M8 screw fittings: 15 Nm

SAFETY INSTRUCTIONS



Planning, installation and start-up of the solar power system are to be done only by qualified professionals. Improper execution can damage the system and the building and endanger people.



Falling hazard! During all work on the roof, and when climbing up and down, there is a risk of falling. Always obey the accident prevention regulations and use appropriate fall protection equipment.



Injury hazard! People can be injured by falling objects. In the hazard area, before starting installation, set up barriers and warn people in the area.



Break hazard! PV modules can be damaged if they are entered or improperly handled.



Electrical current hazard! Installation and maintenance of the PV module must be done only by qualified professionals. Obey the PV module manufacturer's safety instructions!

VERTICAL INSTALLATION

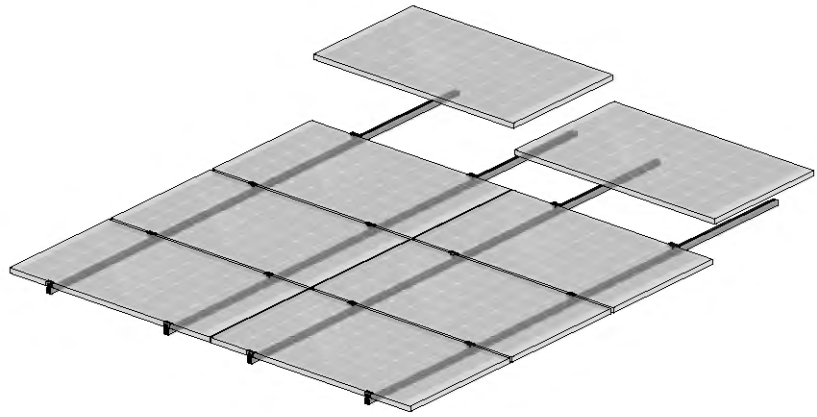

1

PROFILE ARRANGEMENT

Check whether the arrangement of the module bearing profile corresponds to your module configuration.

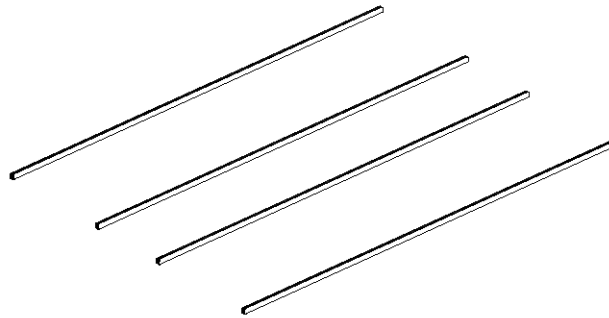

Observe the clamping points in the manufacturer data.

2

INSTALLING THE FIRST MODULE

- Place the module on the profile ends
- Align the module
- Click in the 2 Rapid¹⁶ end clamps and tighten the screws (TX drive T40).
- Connect the module cable accordingly.



Insert end clamps at least 10 mm from the end of the profile.

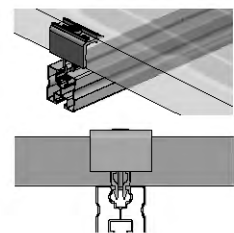
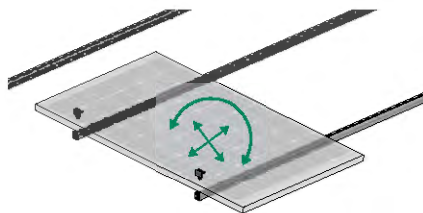

3

INSTALLING FURTHER MODULES

- Click in the 2 Rapid¹⁶ centre clamps
- Set up and align another module
- Connect the module cable accordingly.
- Tighten the screws
- Repeat the steps in order until the last module

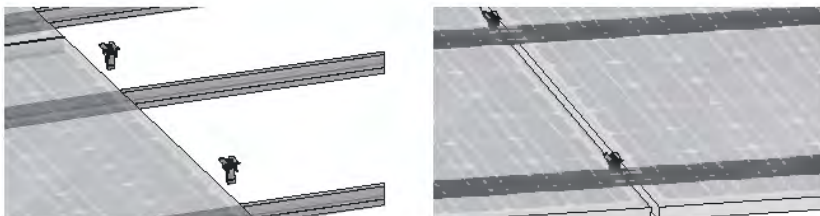

- Observe the module distances (see illustration)
- Distance of modules between the module rows min. 10 mm or according to the module manufacturer's guidelines

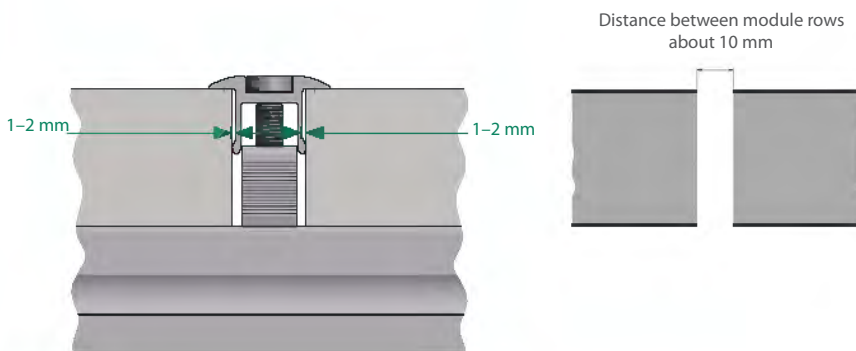

4

INSTALLING THE LAST MODULE

- Click in the 2 Rapid¹⁶ end clamps and tighten the screws



- Please make sure the clamp is in contact with the module frame (see illustration)

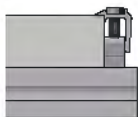

HORIZONTAL INSTALLATION

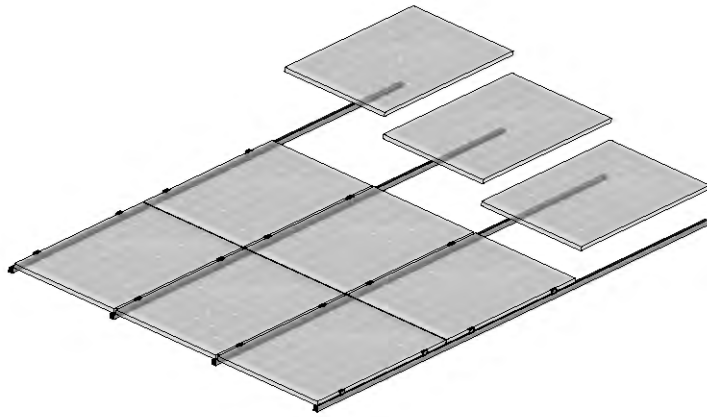

1

PROFILE ARRANGEMENT

Check whether the arrangement of the module bearing profile corresponds to your module configuration.



Observe the clamping points in the manufacturer data.

2

INSTALLING THE FIRST MODULE

- Click in the 2 Rapid¹⁶ end clamps
- Place and align the module on the end clamps
- Tighten the screws on the end clamps (TX drive T40)
- Properly connect the module cable

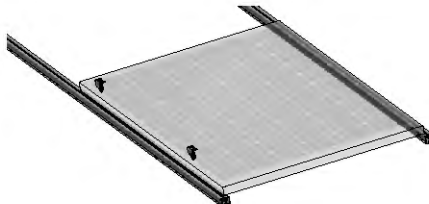

3

INSTALLING FURTHER MODULES

- Click in the 2 Rapid¹⁶ centre clamps
- Set up and align another module
- Connect the module cable accordingly.
- Tighten the screws
- Repeat the steps in order until the last module

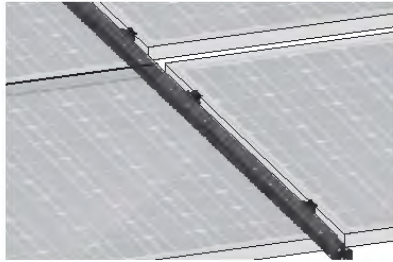

- Observe the module distances (see illustration)

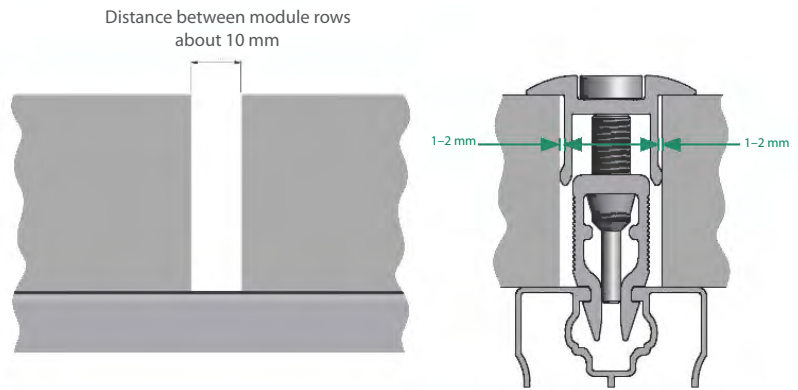

4

INSTALLING THE LAST MODULE

- Click in the 2 Rapid¹⁶ end clamps and tighten the screws
- Distance of modules between the module rows min. 10 mm or according to the module manufacturer's guidelines

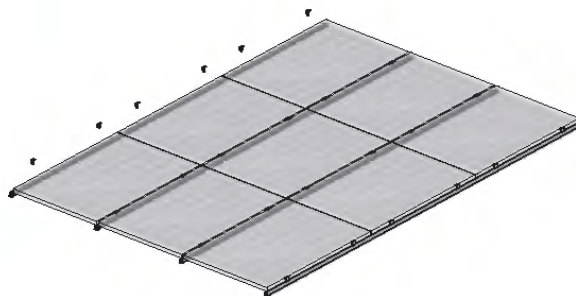

- Please make sure the clamp is in contact with the module frame (see illustration)

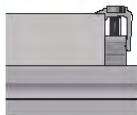

INSTRUCTIONS FOR DISMANTLING

To release or dismantle the module clamps, do as follows:
When releasing the clamps, pull the upper part of the clamp upward together with the screw, so that the clamp is released from the module frame and the screw does not turn out of the upper part of the clamp.

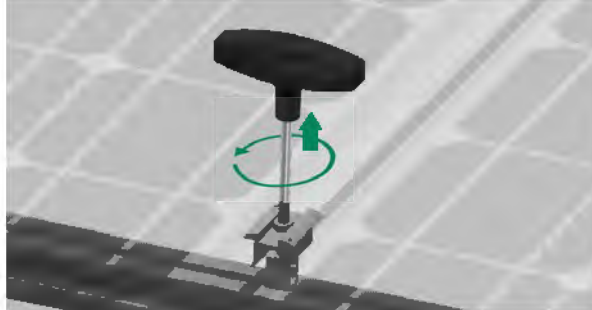

SCHLETTER SOLAR GMBH
Alustrasse 1
83527 Kirchdorf
GERMANY
www.schletter-group.com

