

MultiPlus-II 48/3000/35-32 230V (formerly called MultiGrid-II)

Comparison to the MultiGrid 48/3000/35-50 230V and installation suggestions



1. Specifications

	MultiPlus-II 48/3000/35 230V	MultiGrid 48/3000/35-50 230V
PowerControl & PowerAssist	Yes	
Transfer switch	32 A	50 A
INVERTER		
DC Input voltage range	38 – 66 V	
Output	Output voltage: 230 VAC ± 2% Frequency: 50 Hz ± 0,1% (1)	
Cont. output power at 25°C (3)	3000 VA	
Cont. output power at 25°C	2400 W	
Cont. output power at 40°C	2200 W	
Cont. output power at 65°C	1700 W	
Peak power	5500 W	6000 W
Maximum efficiency	95 %	
Zero load power	11 W	25 W
Zero load power in AES mode	7 W	20 W
Zero load power in Search mode	2 W	12 W
CHARGER		
AC Input	Input voltage range: 187-265 VAC Input frequency: 45 – 65 Hz	
Charge voltage 'absorption'	57,6 V	
Charge voltage 'float'	55,2 V	
Storage mode	52,8 V	
Maximum battery charge current (4)	35 A	
Battery temperature and voltage sensor	VE.Bus Smart dongle (6) (optional)	Yes
GENERAL		
Auxiliary output	Yes (32 A) Directly connected to the AC input	Yes (16 A) Relay with 2 minutes turn on delay
External current 100A sensor (optional)	Yes	No
Programmable relay (5)	Yes, but not the same functionality?	
Protection (2)	a - g	
VE.Bus communication port	For parallel and three phase operation, remote monitoring and system integration	
General purpose com. ports	Yes, Aux in 1 and Aux in 2	
Remote on-off	Yes	
Operating temperature range	-40 to +65°C (fan assisted cooling)	
Humidity (non-condensing)	max 95%	
ENCLOSURE		
Material & Colour	Steel, blue RAL 5012	Aluminium, blue RAL 5012
Protection category	IP 22	
Battery-connection	Two M6 bolts	Four M8 bolts
230 V AC-connection	Screw terminals 13 mm ² (6 AWG)	
Weight	18 kg	
Dimensions (h x w x d)	499 x 268 x 141 mm	362 x 258 x 218 mm
1) Can be adjusted to 60 Hz 2) Protection key: a) output short circuit b) overload c) battery voltage too high d) battery voltage too low e) temperature too high f) 230 VAC on inverter output g) input voltage ripple too high 3) Non-linear load, crest factor 3:1 4) At 25°C ambient 5) Programmable relay which can be set for general alarm, DC under voltage or genset start/stop function AC rating: 230V / 4A, DC rating: 4A up to 35VDC and 1A up to 60VDC 6) Expected to be available in Q3 2018		

2. Block diagrams

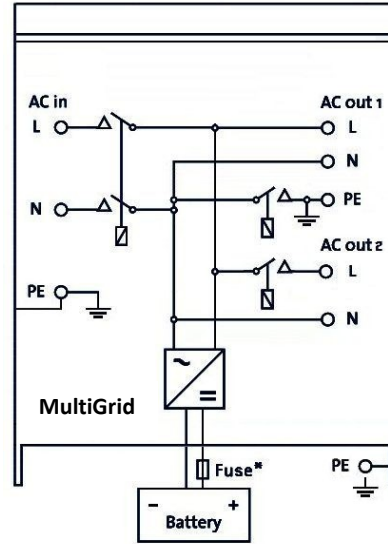
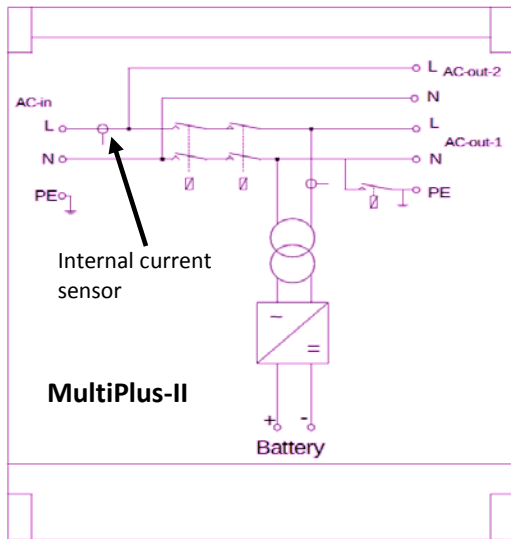

The AC-in current sensor (internal current sensor) of the MultiPlus-II is placed directly on the AC input. AC-out-2 is connected to the AC input, 'downstream' of the current sensor.

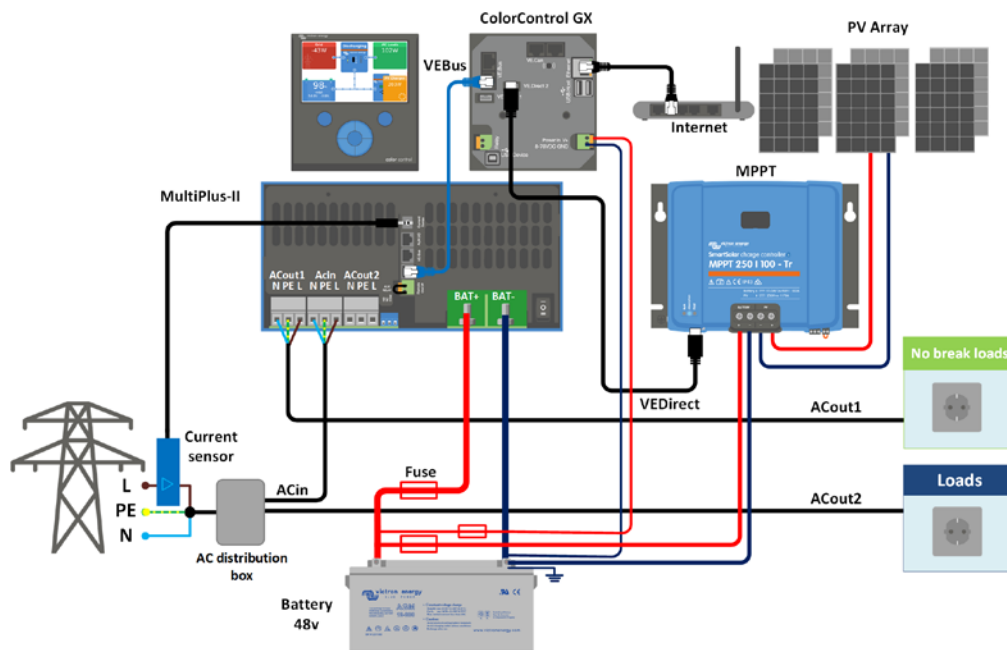

Application example of the external current sensor:

The external current sensor (F) replaces the internal current sensor when connected.

The functionality is identical to the internal sensor.

The external sensor can for example be used to regulate power from the grid to zero, as long as the total load (Loads + No break loads) does not exceed to capacity of the MultiPlus-II, or to implement the PowerAssist function, in systems were the load exceeds the maximum ACin current (35A) of the MultiPlus-II.

3. Analog and digital interfaces

3.1 MultiPlus-II

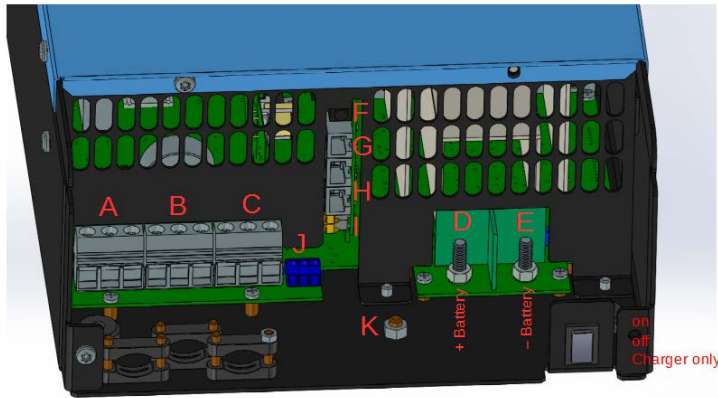

A	Load connection. AC out1. Left to right: N (neutral), PE (earth/ground), L (phase)
B	AC input: Left to right: N (neutral), PE (earth/ground), L (phase)
C	Load connection. AC out2. Left to right: N (neutral), PE (earth/ground), L (phase)
D	M6 battery positive connection.
E	M6 battery minus connection.
F	External current sensor (not available on MGrid)
G	RJ12 additional IO connector (see below)
H	2x RJ45 VE-BUS connector for remote control and/or parallel / three-phase operation (VE.Bus)
I	Connector for remote switch: Short to switch "on".
J	Programmable relay (left to right) NO, NC, COM.(vertual switch in VE.Cofigure)
K	Primary ground connection M8 (PE).

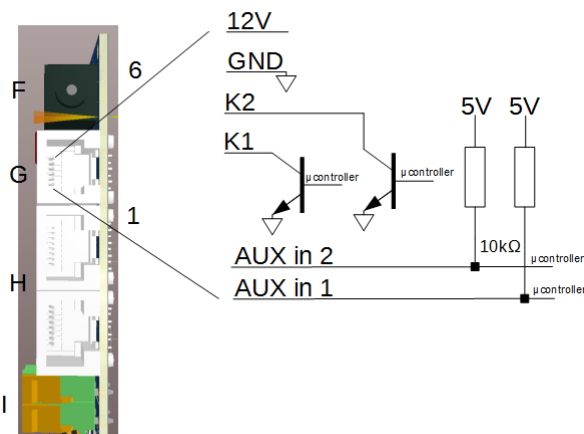

Detail of the RJ12 additional IO connector (G)

RJ12 additional IO connector

Aux in 1 and Aux in 2: 0 – 5V (same fio as in MultiGrid)

K1, K2: open collector 70V 100mA max (open collector inputs, replaces the programmable relay contacts of the MultiGrid)

12V: 12V 100mA max power supply

Gnd: common ground

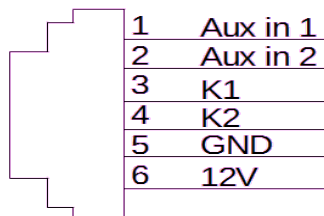

Detail of the RJ12 additional IO connector (G)

3.2 MultiGrid

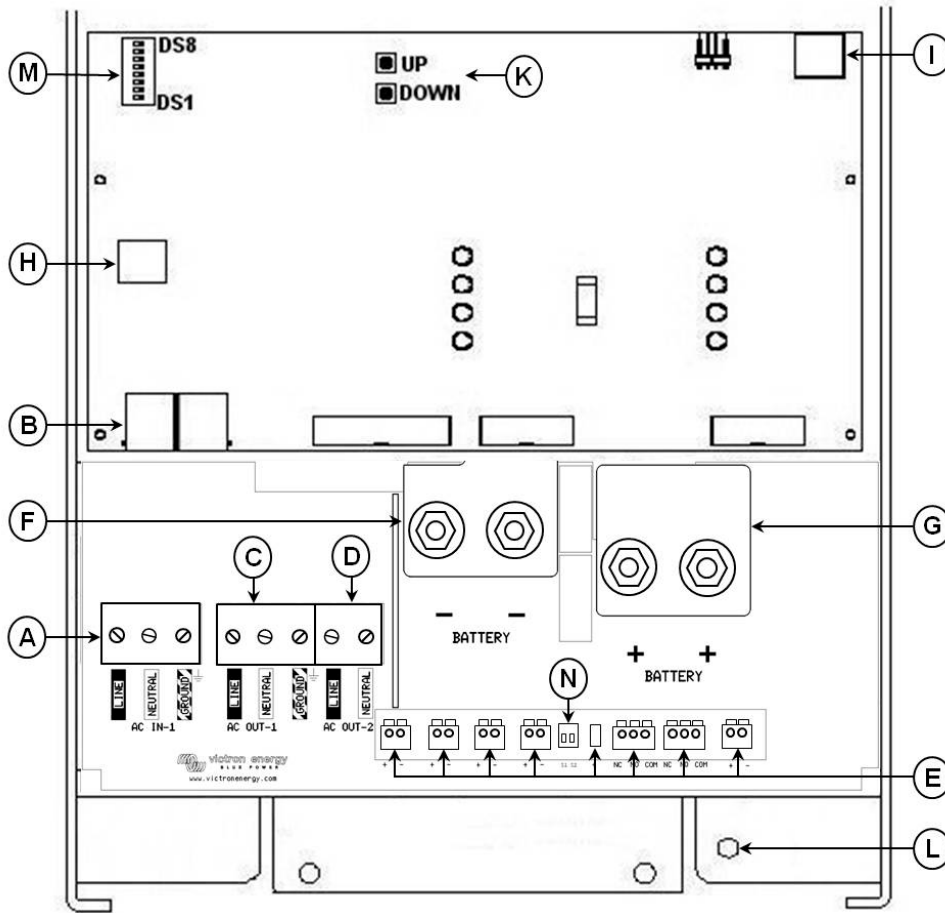

A	AC input: Left to right: L (phase), N (neutral), PE (earth/ground).
B	2x RJ45 connector for remote control and/or parallel / three-phase operation (VE.Bus)
C	Load connection. AC out1. Left to right: L (phase), N (neutral), PE (earth/ground).
D	Load connection. AC out2. Left to right: PE (earth/ground), L (phase), N (neutral).
E	Terminals Temperature sensor (not available on the MultiPlus-II: VE.Bus Smart dongle needed) Aux input 1 (same fio as MultiPlus-II) Aux input 2 (same fio as MultiPlus-II) Starter battery plus + (starter battery minus must be connected to service battery minus) Not available on the MultiPlus-II. Programmable relay contacts K1 Programmable relay contacts K2 Voltage sense (not available on the MultiPlus-II: VE.Bus Smart dongle needed)
F	Double M8 battery minus connection.
G	Double M8 battery positive connection.
H	Connector for remote switch: Short left and middle terminal to switch 'on'. Short right and middle terminal to switch to 'charger only'. Charger only mode not available on MultiPlus-II.
I	Alarm contact: (left to right) NC, NO, COM.
K	Pushbuttons for set-up mode. Not available on MultiPlus-II.
L	Primary ground connection M8 (PE).
M	Dipswitches DS1- DS8 for set-up mode. Not available on MultiPlus-II.
N	Slide switches, factory setting: SW1= down (off) position, SW2 = down (off) position. Not available on MultiPlus-II. SW1: down (off) = internal GND relay selected, up (on) = external GND relay selected (to connect ext GND relay: see E). Not available on MultiPlus-II SW2: No application. To be used for future features. Not available on MultiPlus-II

4 Installation suggestions

Basic with Digital Multi Control
ACout2 through Multi

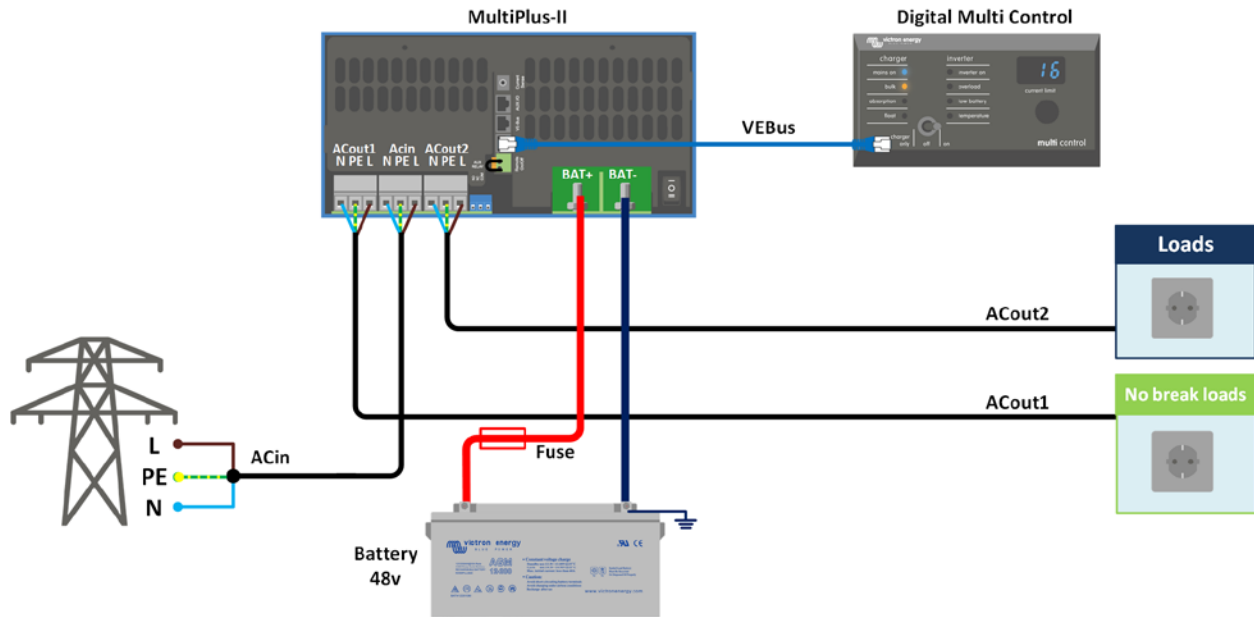

Basic with Digital Multi Control and current sensor
ACout2 from distribution box

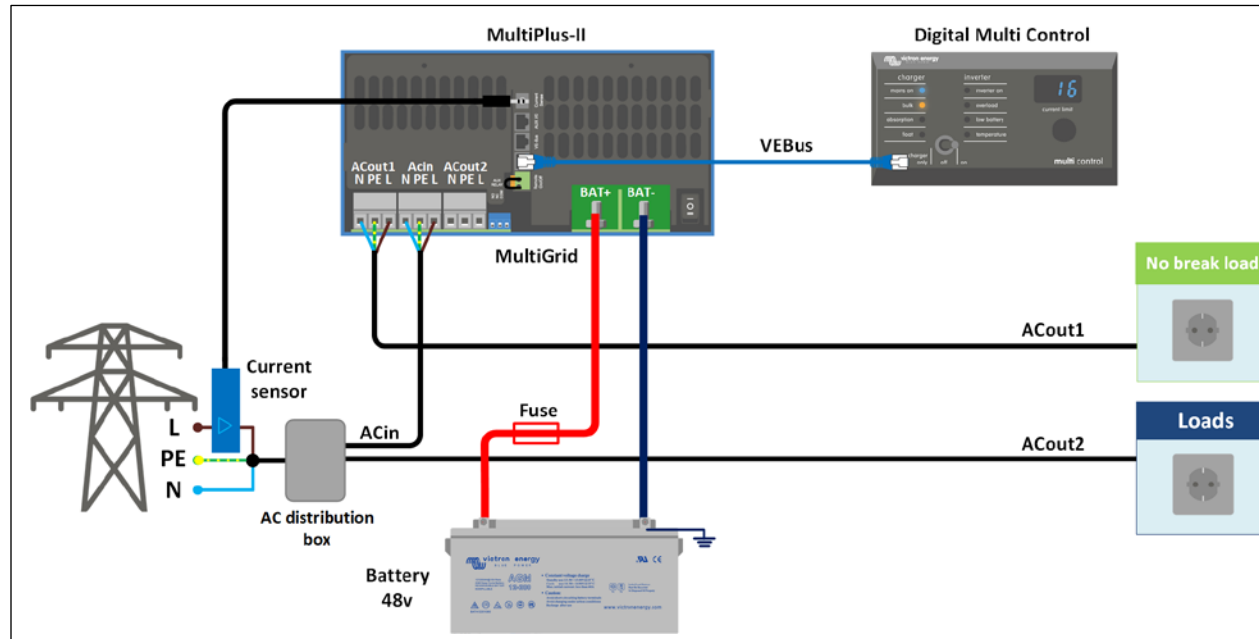

The external current sensor is needed to implement the PowerAssist function when the loads, including the no break load and the power required to charge the battery (max 2200 W) may exceed the maximum ACin current (35A) of the MultiPlus-II.

ESS DC PV
ACout2 through Multi

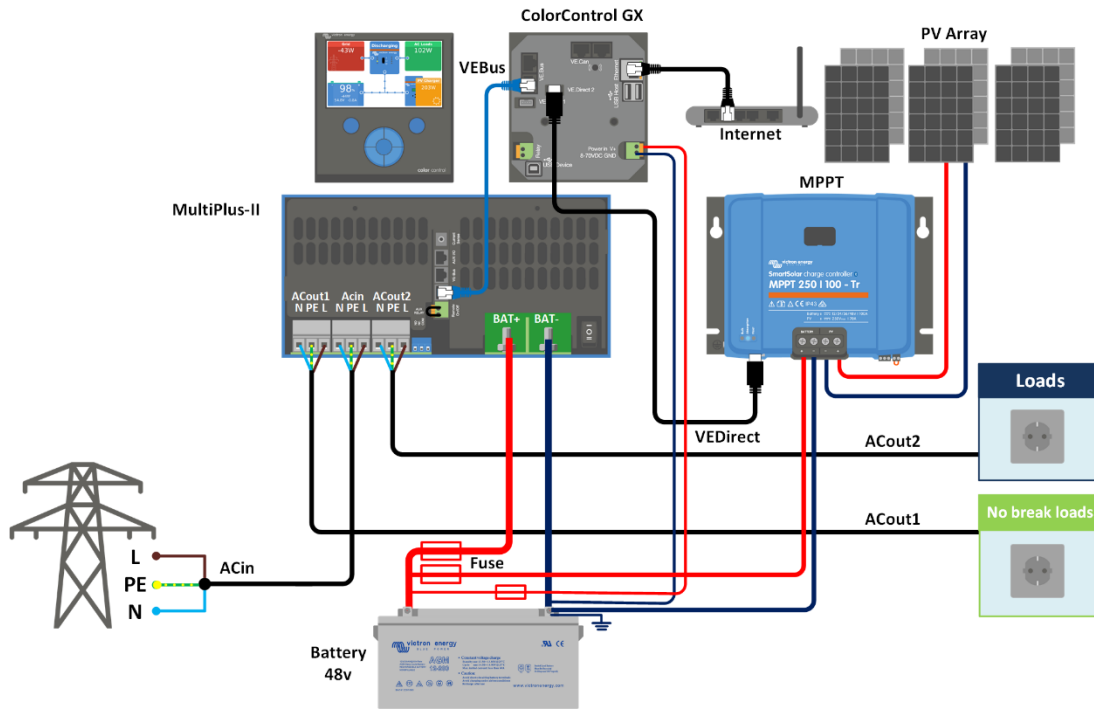

ESS DC PV and current sensor
ACout2 from distribution box

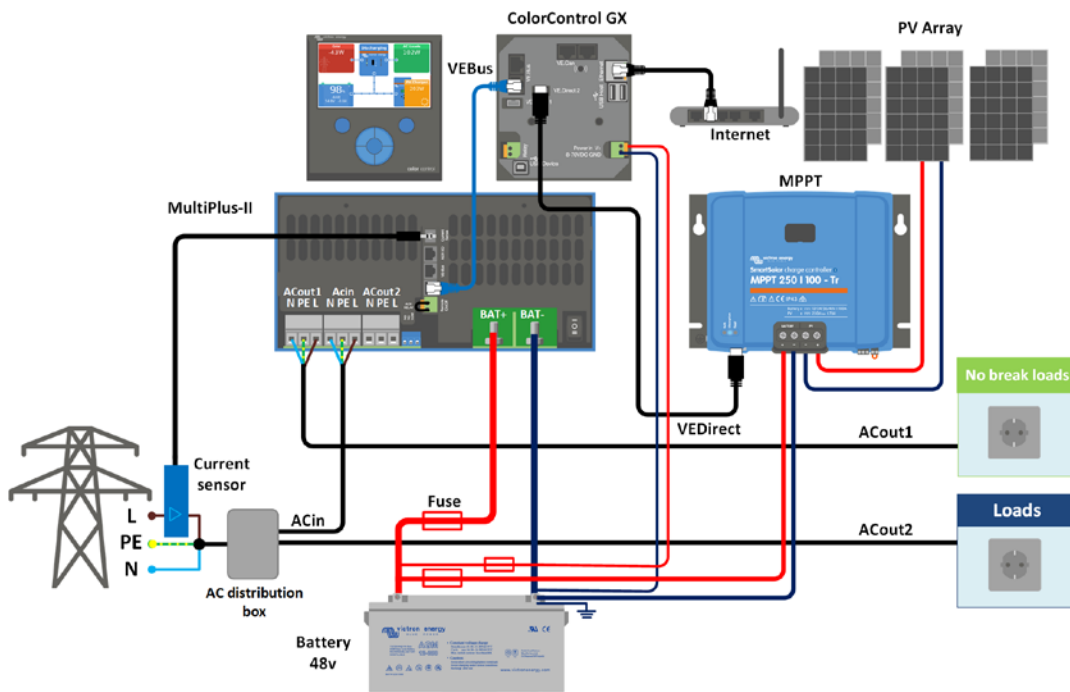

ESS AC PV on output1
ACout2 through Multi

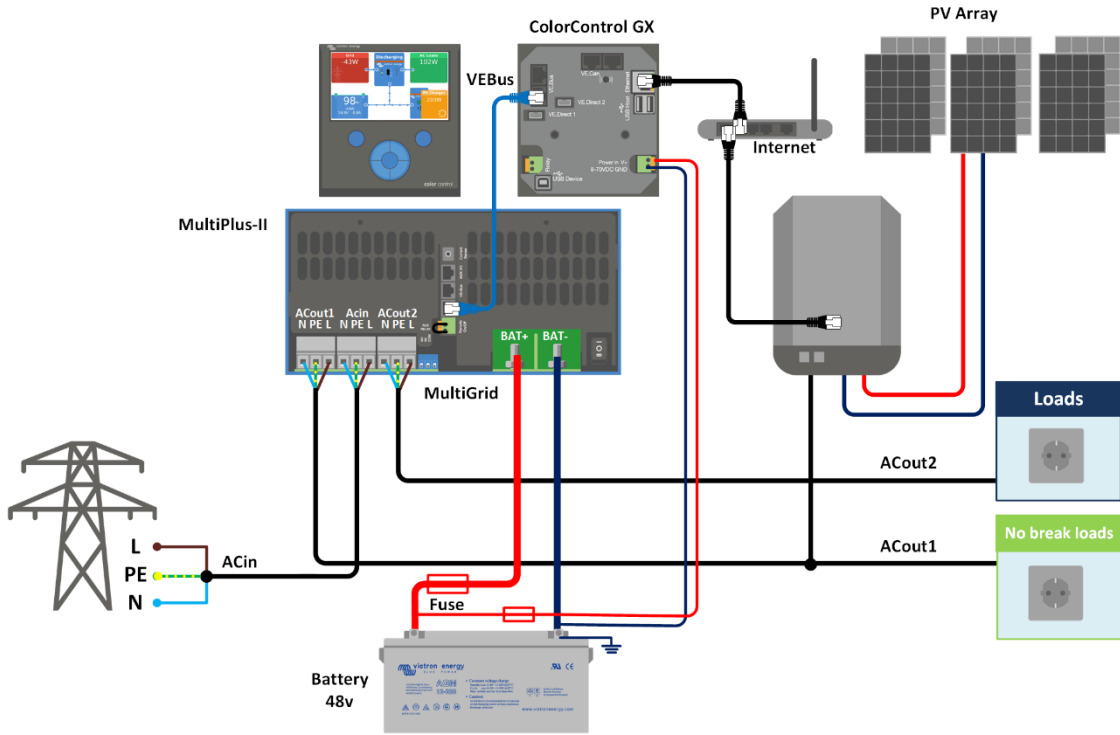

ESS AC PV on output1 and current sensor
ACout2 from distribution box

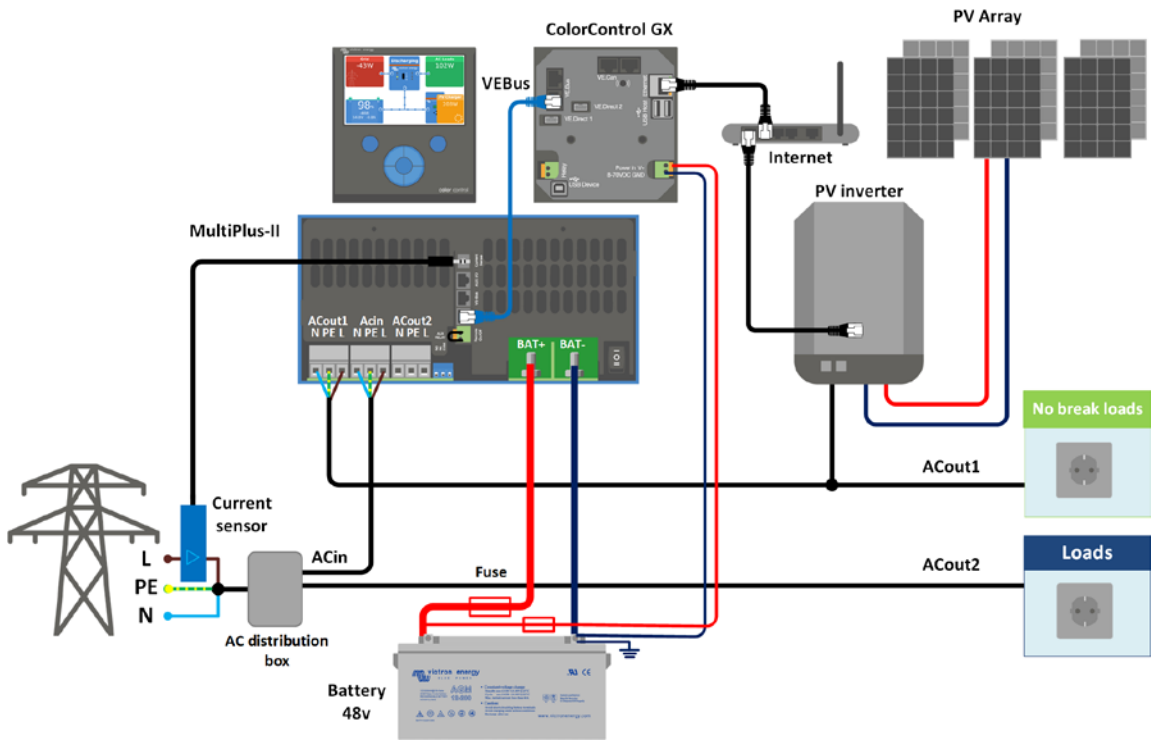

ESS AC PV on input
ACout2 through Multi

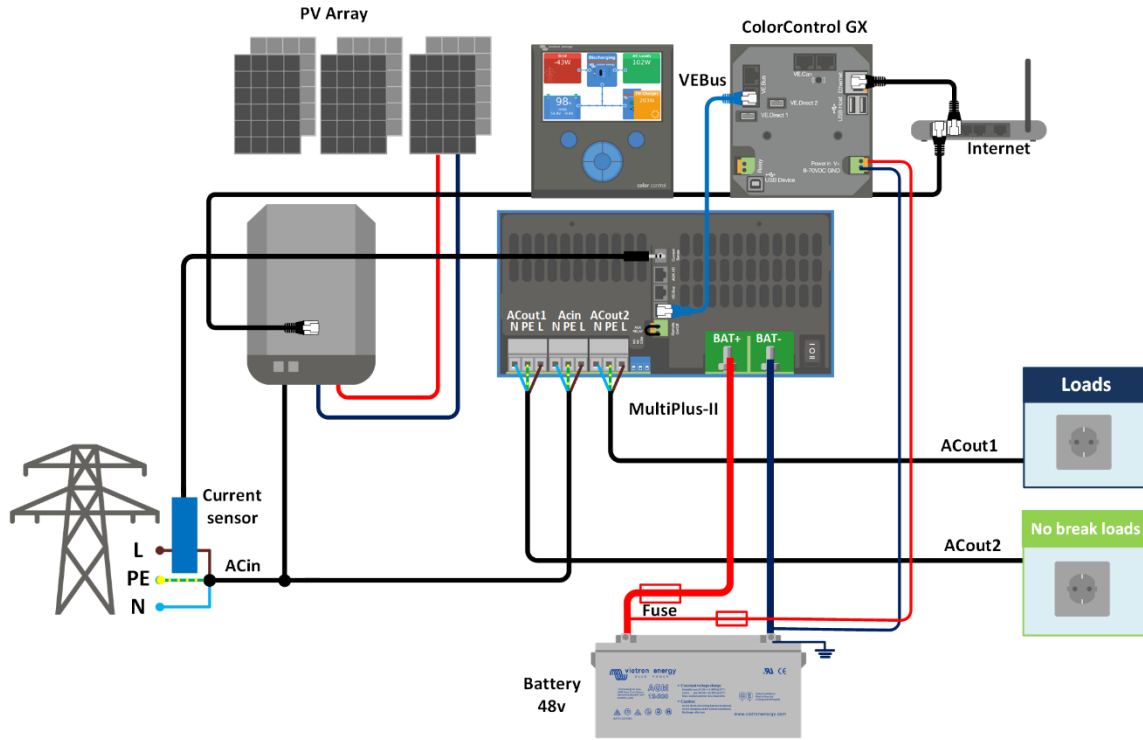

ESS AC PV on input(Output2) and current sensor
ACout2 from distribution box

