

Welcome

Overview, Selection and Installation of DC & AC protection boards

AC and DC Protection Requirements

Training Goals

- Understand Legal Requirements
- Understand System Layout
- Understand Selection Process

AC and DC Protection Legal Requirements

AC and DC Protection Requirements

- AC and DC protection requirements is not an option but a REQUIREMENT
- Safety and protection against electrical shock is the first priority
- Responsibility is that of both installer and the Installation Electrician
- Insurance Companies are now insisting on proof of protection and safety devices

Potential Results of Non-Conformance

Damaged Inverter



Or even worse- damaged Lives



Regulatory Requirements Applicable to AC and DC Boards

Applicable SABS Standards as contained in
DRAFT: SANS 10142-1-2:20XX Edition 1

Subsection: 6.2.7 (Requirement)

Isolation and Switching

- **Isolation shall be provided for the inverter on both the DC and AC side**
- **The solar PV array shall be equipped with devices for isolation and switching**
- **PV strings and PV sub-arrays shall have accessible means of isolation**
- **PV arrays shall have accessible Switch Disconnectors**

Applicable SABS Standards as contained in
DRAFT: SANS 10142-1-2:20XX Edition 1

Subsection: 6.2.7 (Requirement)

Isolation and Switching

- **All Switch Disconnectors shall be selected and erected to comply with the following requirements**
 - 1. It shall not have exposed live metal parts in connected or disconnected states**
 - 2. It shall be DC rated at the calculated maximum voltage and current**
 - 3. The DC Switch Disconnector shall comply with SANS 60947-1 and 3, and SANS 60947-2, when circuit breakers are used**

Applicable SABS Standards as contained in
DRAFT: SANS 10142-1-2:20XX Edition 1

Subsection: 6.2.7.1 (Requirement)

Location of the Switch Disconnecter for Inverter

All Switch Disconnectors shall be selected and erected to comply with the following requirements

- 1. The Switch Disconnecter shall be located such that maintenance of the inverter (e.g., the replacing of modules and fans, or the cleaning of filters) is possible without risk of electrical hazards shall be DC rated at the calculated maximum voltage and current**
- 2. For multiple DC inputs, these requirements apply to each input**

Applicable SABS Standards as contained in
DRAFT: SANS 10142-1-2:20XX Edition 1

Subsection: 6.2.9 (Requirement)

DC Combiner Boxes

DC combiner boxes shall be required when PV Sub-Arrays are combined, or where overcurrent protection and / or switch disconnection devices are used (Protection Boxes)

Applicable SABS Standards as contained in
DRAFT: SANS 10142-1-2:20XX Edition 1

Subsection: 6.2.9.1 (Requirement)

Component Requirements

- **Where protective measures used on the DC side is double or reinforced insulation, combiner boxes shall be selected according to Class II or equivalent insulation, as per SANS 61140**
- **Combiner boxes shall comply with SANS 61439-2. Alternatively, in the event of household or similar solutions only, combiner boxes may comply with SANS 60670 (relevant parts)**
- **Switchgear assemblies shall comply with SANS 61439 (relevant parts)**

Applicable SABS Standards as contained in
DRAFT: SANS 10142-1-2:20XX Edition 1

Subsection: 6.2.9.2 (Requirement)

Accessibility Requirements

- **Combiner boxes that contain overcurrent and / or Switching Devices shall be accessible for inspection, maintenance and / or repairs without necessitating the dismantling of the structural parts (such as cupboards, benches or the like)**
- **Combiner boxes shall be accessible from ground level, i.e., no ladder or scaffolding is required to reach the boxes.)**

Applicable SABS Standards as contained in
DRAFT: SANS 10142-1-2:20XX Edition 1

Subsection: 6.2.9.3 (Requirement)

Wiring in Combiner Boxes

- All cable entries shall maintain the IP rating of the enclosure
- Where conductors enter a combiner box without a conduit, a tension relief arrangement shall be used to avoid cable disconnection inside the box.
- Note 1: Using a gland-connector could serve as a tension relief arrangement
- Note 2: Water condensation inside combiner boxes can be a problem in some locations – in these cases, provision should be made to drain water build-up.

PV SYSTEM EARTHING **NB!!**

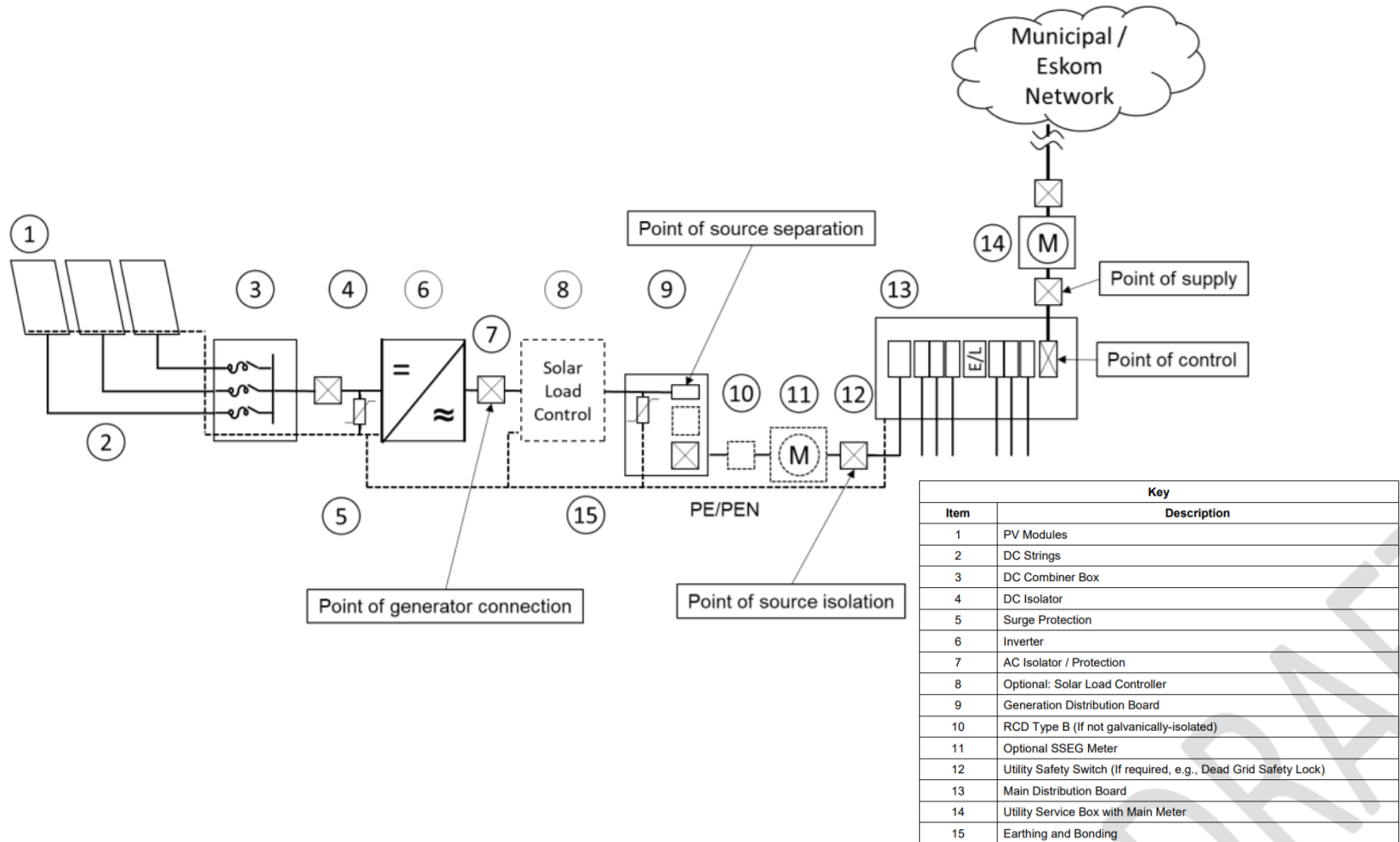

DC Protection & Combiner Boards

How it fits together....

2 x DCB-NF-6I-1000V-I16A-I-II-60
DC String Protection Boards

60kW AC Protection Board



Solis 60K-4G-FB 4 x MPPT inverter

DC Protection & Combiner Boards

How it fits together....

2 x DCB-NF-6I-1000V-I16A-I-II-60
DC String Protection Boards

60kW AC Protection Board
For 1 x Inverter



Solis 60K-4G-FB 4 x MPPT inverter
3 x strings per MPPT (12 strings total)

DC Protection & Combiner Boards

How do I determine if I require a Protection of Combiner Board?

Protection Board

A protection board is required where individual strings are required to be protected
For example- 1 string from the PV array is connected to a single input on an inverter

Combiner Board

A Combiner board is required where Multiple strings are required to be protected
For example- 6 strings from the PV array is connected to a single input on an inverter

DC Protection & Combiner Boards

Protection Board Example



Solis Mini 700w Inverter

1 String input and 1MPPT

DC Protection & Combiner Boards

Protection Board Example



Solis 3600w Inverter

2 String input and 2MPPT

DC Protection & Combiner Boards

Combiner Board Example



Victron 150/100
Charge controller

1 String input and 1MPPT

DC Protection & Combiner Boards

Combiner Board Example

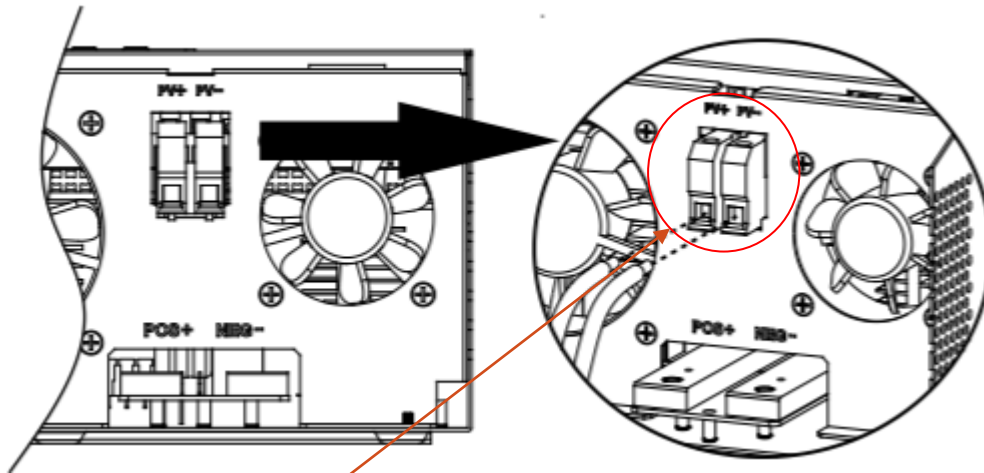

Kodak 5KVa Off Grid
Inverter

1 String input and 1MPPT

DC Protection & Combiner Boards

How do I select the correct Protection Board?

1. Select the inverter of choice
2. Consult the DC input data of the selected inverter paying attention to the following:
 - A. DC Input Voltage Max Mpp Voc- Open Circuit Volatge ie: 600V
 - B. Number of MPP Trackers ie: 1
 - C. Max DC input Current: ie: 12Amp
 - D. Number of Strings / MPPT ie: 1

Datasheet

Model	Solis-mini-700-4G	Solis-mini-1000-4G	Solis-mini-1500-4G	Solis-mini-2000-4G	Solis-mini-2500-4G	Solis-mini-3000-4G
Energy Source	PV					
Input Side(DC)						
Max. DC input power(kW)	0.9	1.2	1.8	2.3	3	3.5
Max. DC input voltage(V)	600					
Start-up voltage(V)	60			90		
MPPT voltage range(V)	50-500			80-500		
Max. input current(A)	11A					
MPPT number/Max input strings number	1/1					

DC Protection & Combiner Boards

How do I select the correct Protection or Combiner Board?

1. Considering the previous slide information and the data below choosing the right part number
 - A. DC Input Voltage Max Mpp Voc- Open Circuit Volatge ie: 600V
 - B. Number of MPP Trackers ie: 1
 - C. Max DC input Current: ie: 12Amp
 - D. Number of Strings / MPPT ie: 1

Decrypting the part number

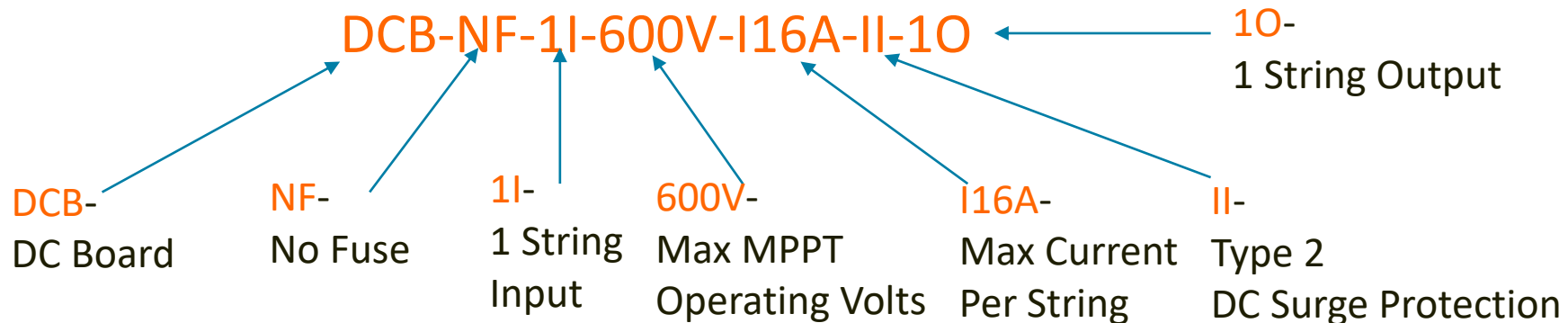

DC Protection & Combiner Boards

How do I select the correct Combiner Board?

1. Select the inverter or charge controller of choice
2. Consult the DC input data of the selected inverter paying attention to the following:
3. NOTE: All connected strings on a combiner board must have equal amount of PV modules
 - A. DC Input Voltage Max Mpp Voc- Open Circuit Volatge ie: 145V
 - B. Number of MPP Trackers ie: 1- Refer connection Diagram
 - C. Max DC input Current: ie: 80Amp
 - D. Number of Strings / MPPT ie: 1- Refer Connection Diagram
 - E. NB-Keep in Mind the Max PV Array Power (4000W)

SOLAR CHARGER & AC CHARGER

Solar Charger Type	MPPT	MPPT
Maximum PV Array Power	1500 W	4000 W
MPP Range @ Operating Voltage	30 - 115 VDC	60-115VDC
Maximum PV Array Open Circuit Voltage	145 VDC	145 VDC
Maxmum Solar Charge Current	60 A	80 A
Maximum AC Charge Current	60 A	60 A

DC Protection & Combiner Boards

How do I select the correct Combiner Board?

1. Calculate PV Array power vs. Max MPPT Voltage VS Max Input Current
 - A. Max PV Power- $4000w / 340Wp \text{ Module} = 11,74$ (3991.6Wp) (12 Panels) - 4080Wp
 - B. Max MPPT Voltage: $145 \text{ Vdc} - 41,36\text{Voc}$ 340w panel Voltage / $145\text{Voc} = 3,5$ panels/string (3)
 - C. Number of Strings : $12 \text{ panel} / 3 \text{ panels per string} = 4$ strings
 - D. String Combiner Boards required each string to be FUSED (regulatory)

Decrypting the part number

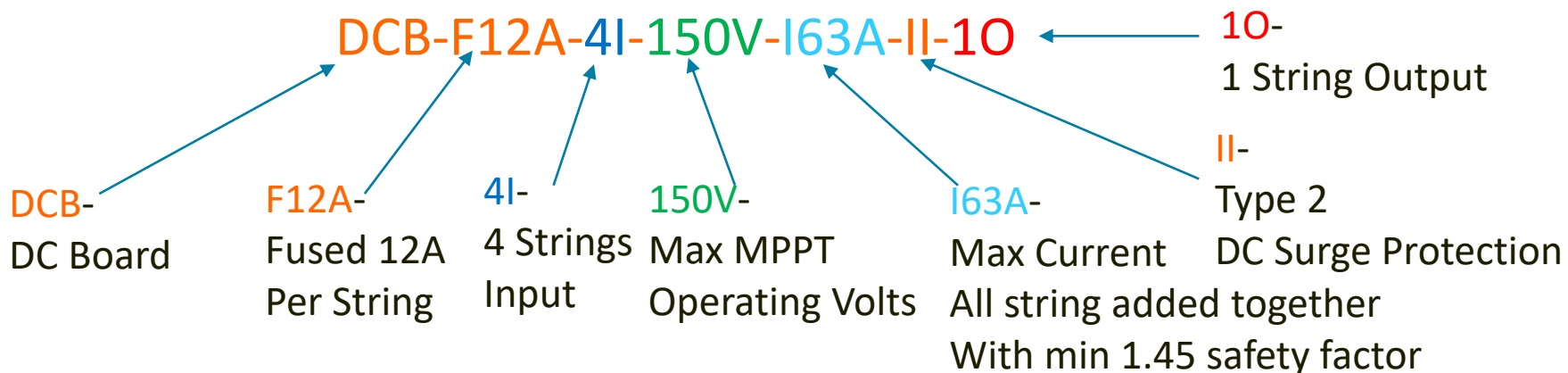

Solis 180KW PV System with EPM3-5G-PLUS- NO GENERATOR INTEGRATION SOLUTION

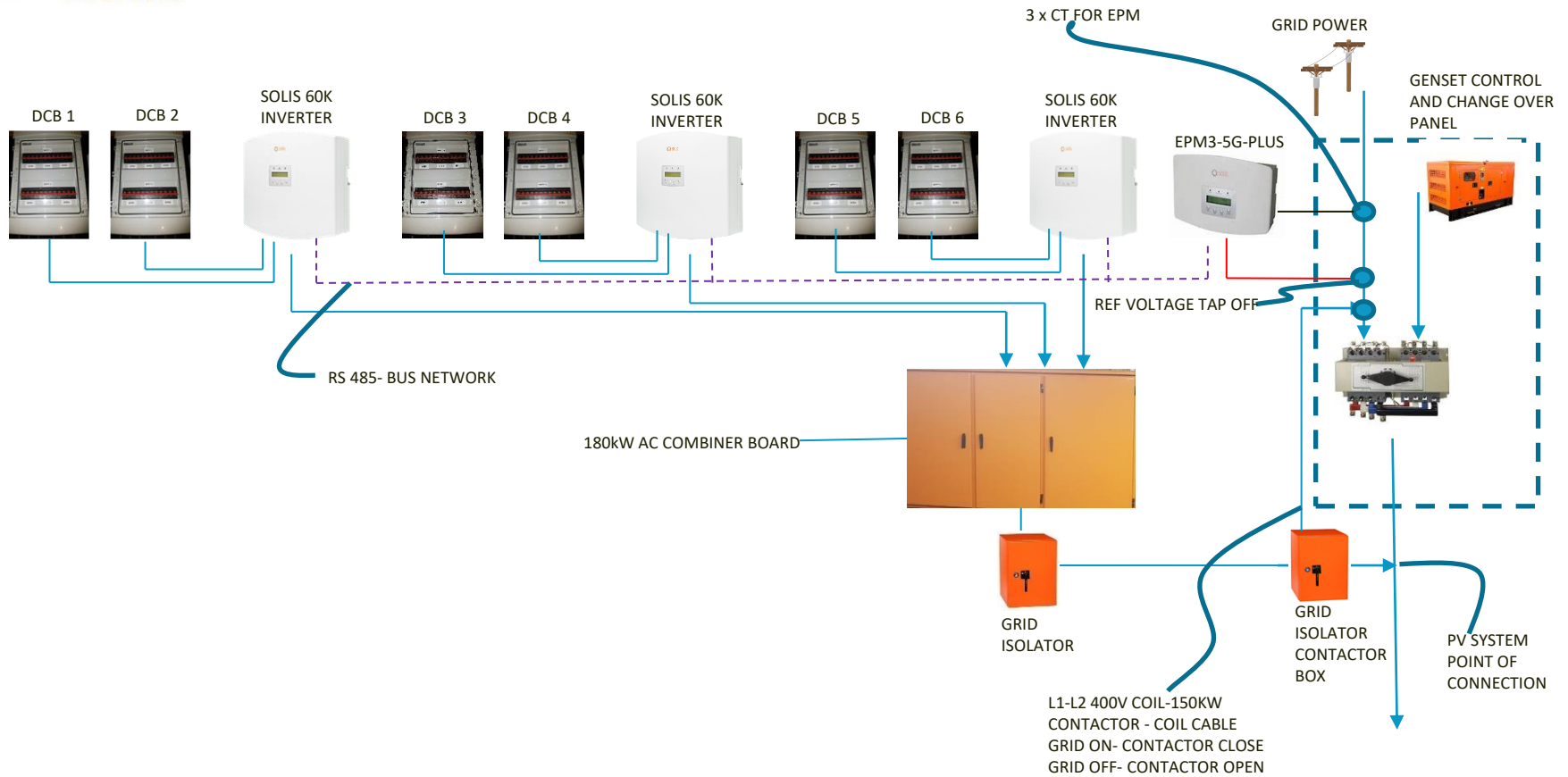

Multiple System AC Combiner Boards

Main Components to the AC Boards?

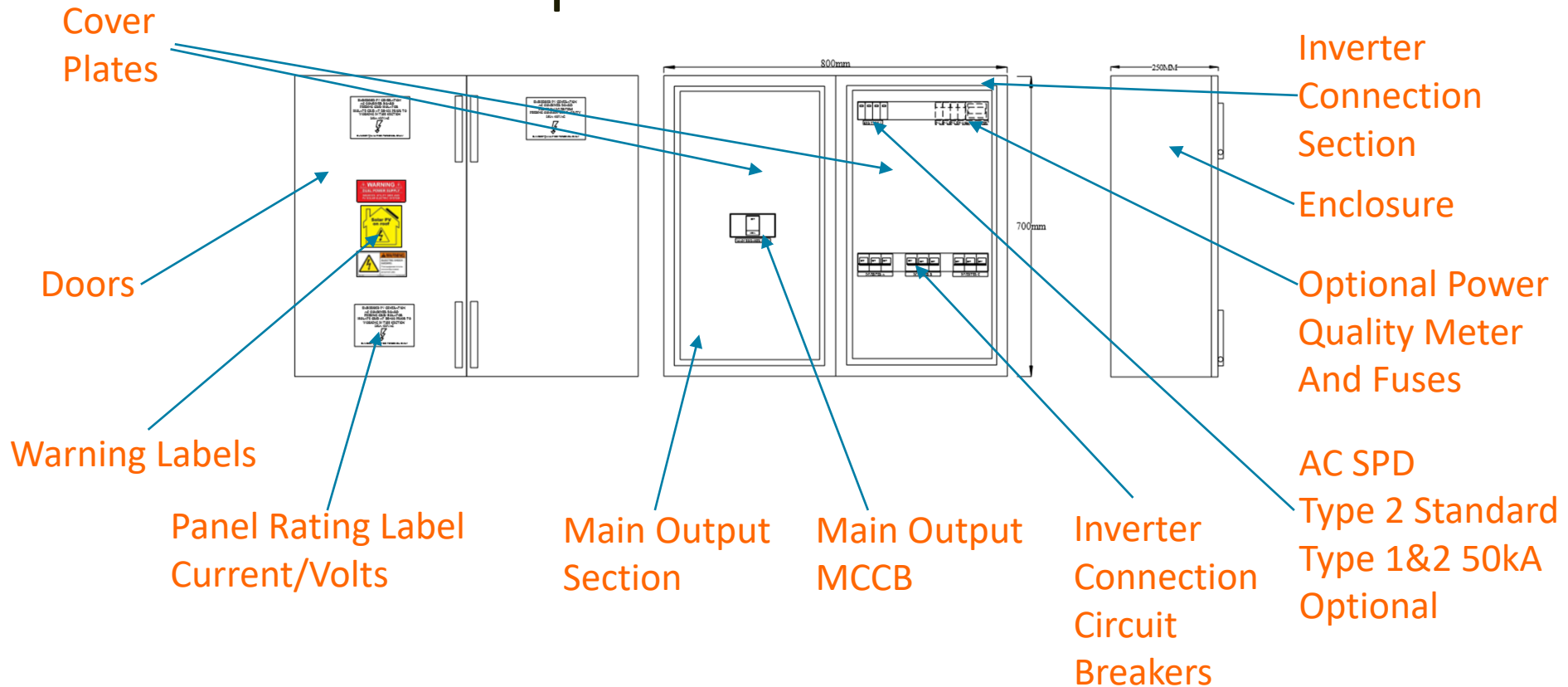

NEW AC INPUT AND OUTPUT BOARD FOR RESIDENTIAL APPLICATIONS WITH HYBRID AND OFF GRID APPLICATIONS



NEW AC INPUT AND OUTPUT BOARD FOR RESIDENTIAL APPLICATIONS WITH HYBRID AND OFF GRID APPLICATIONS

- The new AC input and output Board caters for both the grid in put the inverter
And the inverter output to the loads
- Type 2 AC SPD as standard
- Grid Input Breaker (2 Pole)
- Back up Main Breaker (2 Pole)
- 30mA 2P 25A Earth Leakage Unit
- 16Amp (1Pole) Plugs out Breaker
- 10Amp (1Pole) Lights Output Breaker
- IP 65 Enclosure
- PVC Compression Glands for cable entries
- Currently Suitable for H4.6 and 5KVA off grid Kodak Inverters
- Others under development

RESIDENTIAL APPLICATIONS - TYPICAL LATOUT

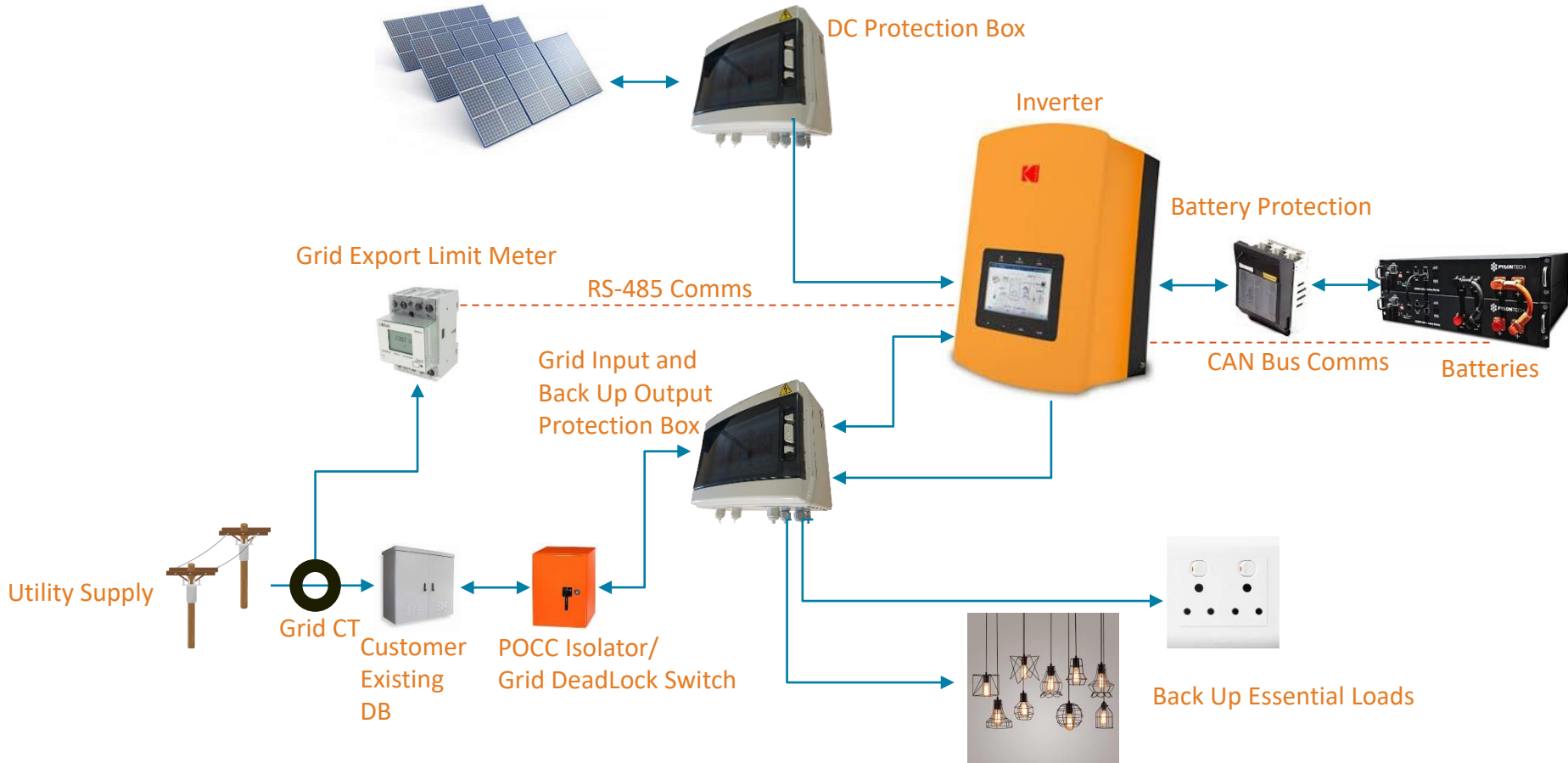

PV SYSTEM EARTHING NB!!

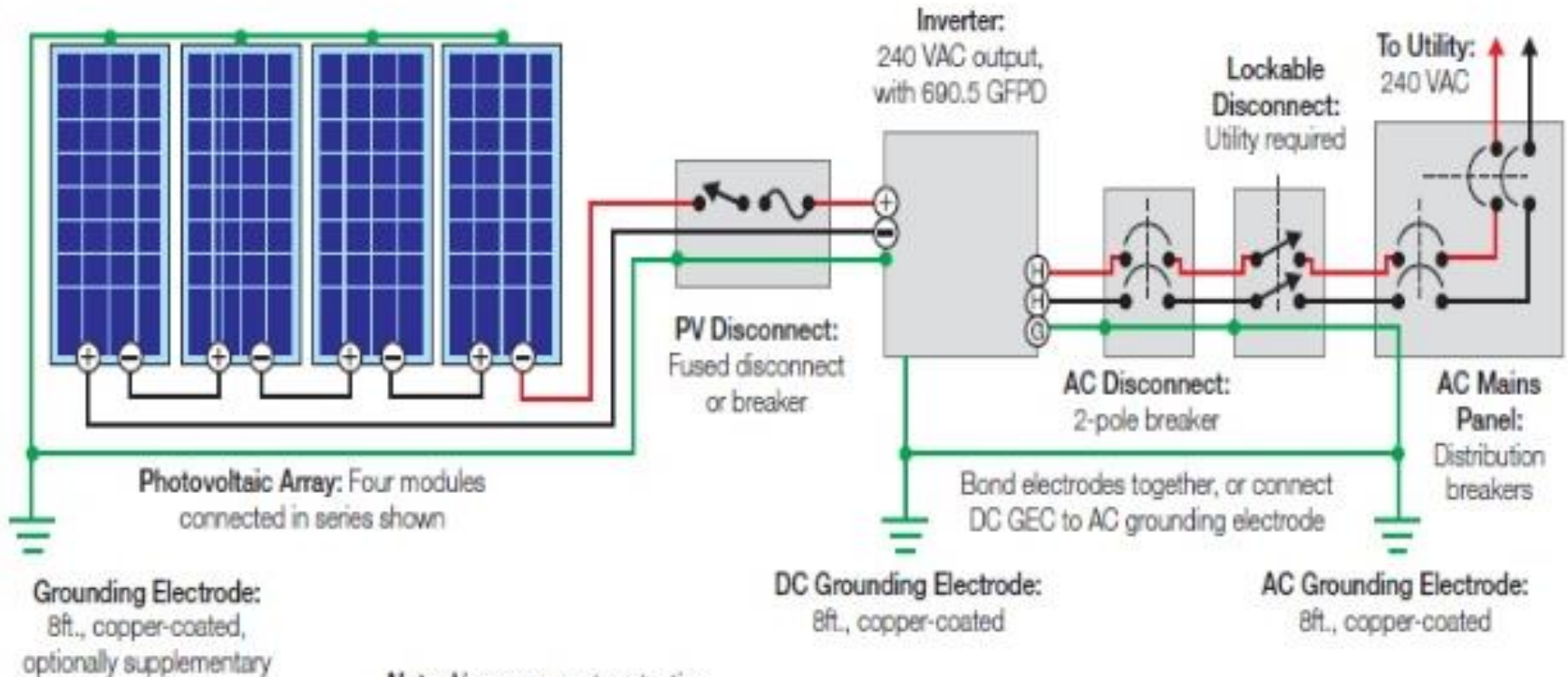

Note: No overcurrent protection needed with some inverters

Thank you

To recap on today's webinar please visit our portal

